

Electrical Discharge

for accumulator charging valves

- NG 06 ISO 4401
- NG 10 ISO 4401
- Kit / block mounting

- Unpressurised machine start up
- Electrical accumulator relief



Symbol:

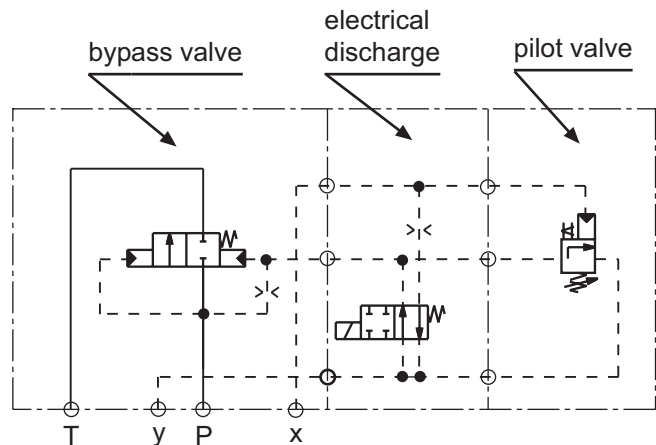

Dimension drawing:

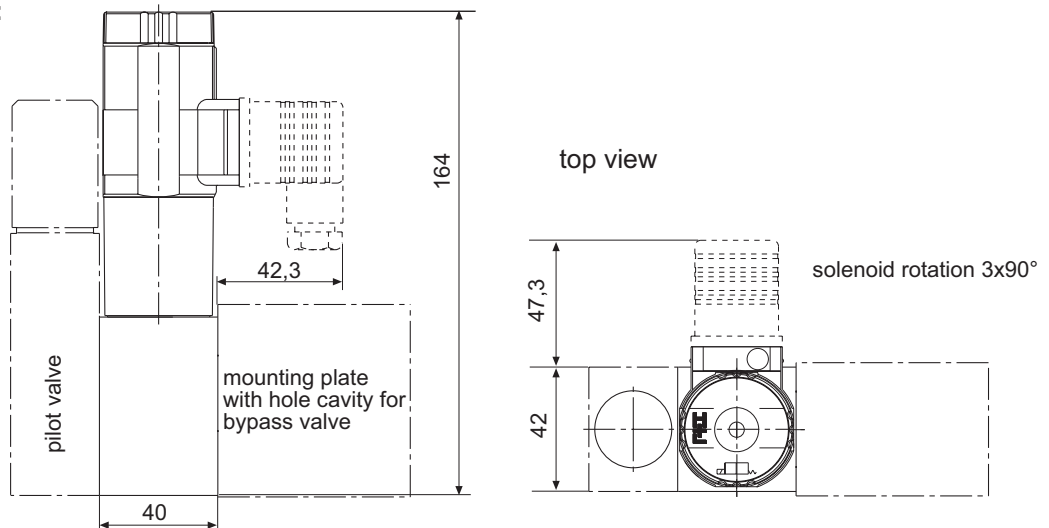

Type code:

Id.-Nr. (specified by the factory)
Pressure valve option
Symbol
Orifice accumulator drain
Design
Design code

D z 5 2 - 1 2 0 Z 3 0 0 R 0 2 4 / 0 H N

Manual emergency operation
Electric interface
H= connector DIN 43650
M= connector M12
Power supply / Voltage
024/0= 24V DC
220/5= 230V/50Hz
Solenoid type
R= single solenoid
Z= double solenoid

The specifications given herein are subject to alteration