

COMPACT CYLINDERS SERIES "CMPC" Ø 12÷100



1

Compact cylinder series CMPC available in numerous versions to meet a full range of requirements:

- With or without magnet
- Single-acting extended rod, retracted or through-rod
- Dual-acting non-rotating and dual-acting through-rod versions
- Tandem with two, three or four stages
- Multi-position with two and three stages
- Fixing centre distances to ISO 6431 – VDMA 24562 from Ø 32 to Ø 100 and from Ø 20 to Ø 100 complying with French standard NFE 49-004-1 and 2 (UNITOP). Ø 12 and Ø 16 have centre distances compatible with trade cylinders.

The special profile and outer heads locked onto the jacket by screws ensure optimal guiding of the cylinder and multiple fixing options with a wide range of mountings. To determine the position in the relevant cylinder slots, it is possible to mount retracting magnetic limit switches.

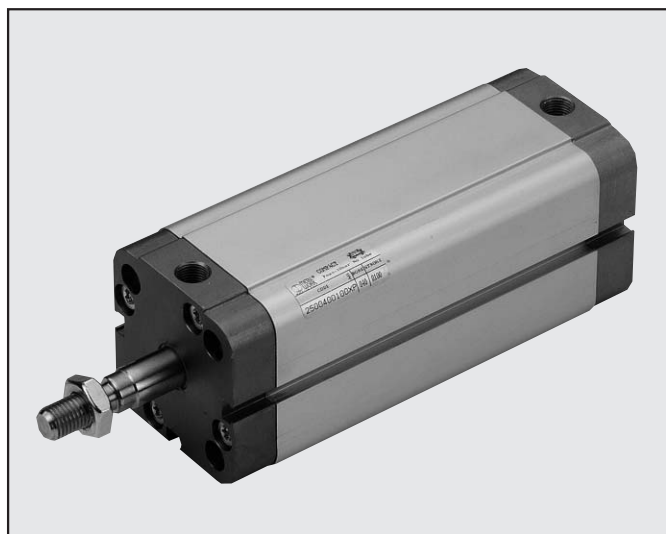

TECHNICAL DATA	POLYURETHANE
Operating pressure	max 10 bar (max 1 MPa-145 psi)
Temperature range	-10°C to +80°C
Fluid	Unlubricated air. Lubrication, if used, must be continuous.
Bores	mm Ø12, Ø16; interchangeable with similar products
	mm Ø 30, Ø 40, Ø 50, Ø 63, Ø 80 and Ø 100 with ISO 6431 VDMA24562 fixing centre distances.
	mm Ø 20, Ø 25, Ø 32, Ø 40, Ø 50, Ø 63, Ø 80 and Ø 100 with NFE 49-004-1 and 2 fixing centre distances.
Design	With profile, heads with screws
Versions	Double-acting, Single-acting extended or retracted rod, Through-rod, Through-rod perforated, Single-acting through-rod, Through-rod non-rotating.
	All versions are available with male or female piston rod.
Magnet for sensors	All versions come complete with magnet. Supplied without magnet on request.
Inrush pressure	As required
Notes	For correct operation, it is advisable to use 50µm filtered air
Inrush pressure	Ø 12 to Ø 32: 0.6 bar - Ø 40 to Ø 100: 0.4 bar
Forces generated at 6 bar thrust/retraction	See GENERAL TECHNICAL DATA PAGE 1.1/05
Weights	See GENERAL TECHNICAL DATA PAGE 1.1/06

COMPONENTS Ø 12÷25

- ① PISTON ROD: stainless steel, thick chromed
- ② HEAD: extruded anodised aluminium alloy
- ③ JACKET: drawn anodised and calibrated aluminium alloy
- ④ PISTON GASKET: polyurethane
- ⑤ MAGNET: neodymium
- ⑥ PISTON ROD GASKET: polyurethane
- ⑦ GUIDE BUSHING: steel strip with bronze and PTFE insert.
- ⑧ STATIC O-RINGS: NBR
- ⑨ SECURING SCREWS: zinc-plated steel

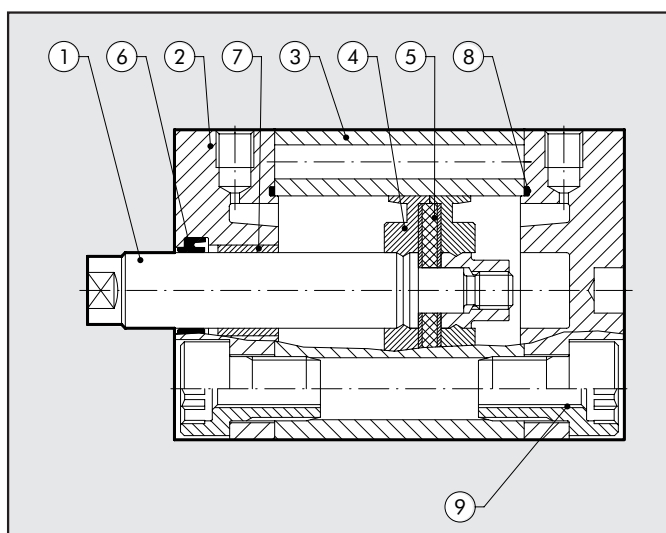

COMPONENTS Ø 32 ÷ 100

- ① PISTON ROD: C45 steel or stainless steel, thick chromed
- ② HEAD: extruded anodised aluminium alloy
- ③ JACKET: drawn anodised and calibrated aluminium alloy
- ④ PISTON GASKET: polyurethane
- ⑤ MAGNET: Ø 12 ÷ 32 neodymium - Ø 40 ÷ 100 plastoferrite
- ⑥ PISTON ROD GASKET: polyurethane
- ⑦ GUIDE BUSHING: steel strip with bronze and PTFE insert.
- ⑧ STATIC O-rings: NBR
- ⑨ SECURING SCREWS: zinc-plated steel

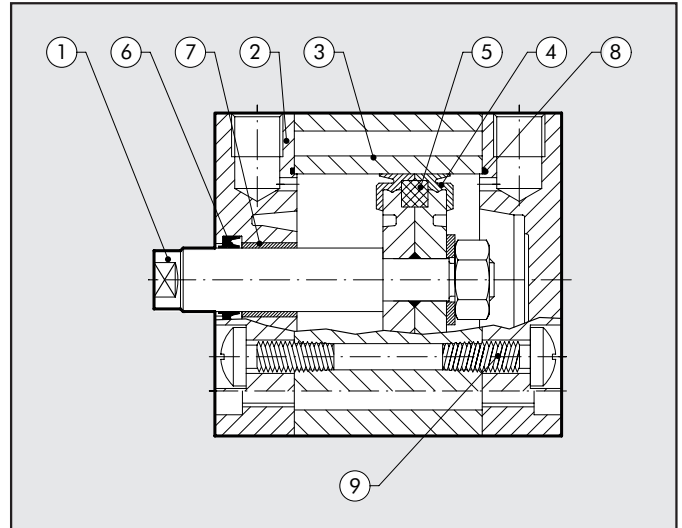

TECHNICAL DATA

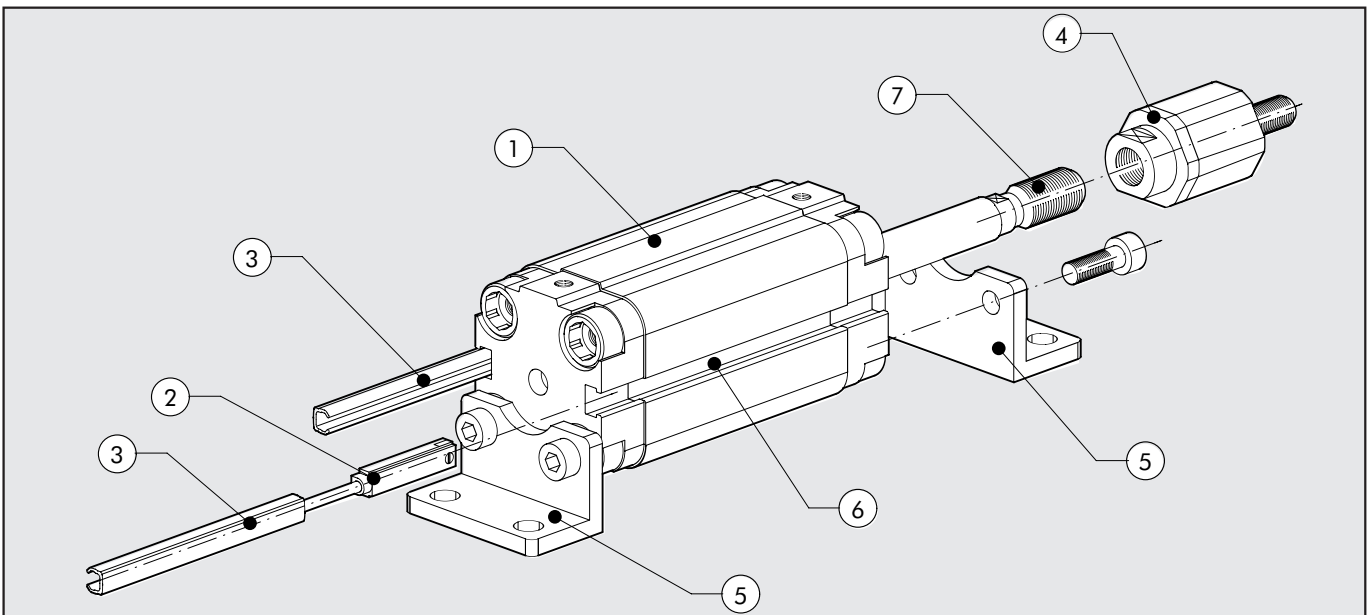

- ① Compact cylinder available with two separate fixing centre distances
 - Ø 32 ÷ 100 to ISO 6431 VDMA24562
 - Ø 20 ÷ 100 to NFE 49-004-1 and 2
- ② Pre-wired retracting sensor with or without connector
- ③ Plastic strip to keep out dirt and/or protect the sensor wire cod. W0950000160
- ④ Ball-and-socket joint code W095... 2030
- ⑤ Example of cylinder mounting with feet code W095... 6001
All mountings come complete with cylinder assembly screws
- ⑥ Sensor slot
- ⑦ Piston rod with male or female thread as required



COMPACT CYLINDER FIXING OPTIONS

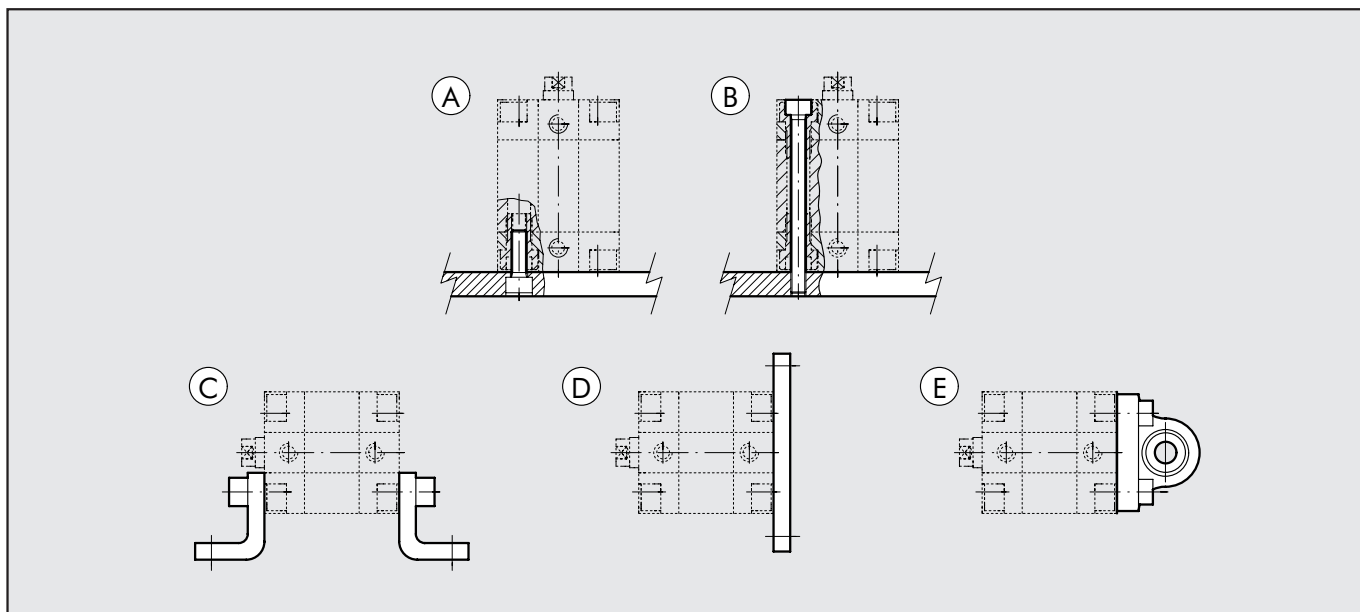

Fixing to structural work with a through screw, using the thread in the heads (Fig. A)
 Direct fixing from above using long through screws or tie rods (Fig. B). Non-magnetic stainless steel must be used (e.g. AISI 304)
 Fixing with feet; the ordering code covers the supply of one foot and two screws for fixing to the cylinder (Fig. C).
 Fixing with a flange mounted on the front or rear head; the ordering code covers the supply of a flange and four screws for fixing to the cylinder (Fig. D).
 Fixing with articulated hinge to compensate for slight system misalignment and turn freely (Fig. E).
 The ordering code covers the supply of a hinge and four screws for fixing to the cylinder.

FORCE OF SPRINGS IN SINGLE-ACTING CYLINDERS (THEORETICAL)

Bore	Ø 12	Ø 16	Ø 20	Ø 25	Ø 32	Ø 40	Ø 50	Ø 63	Ø 80	Ø 100
Min. load (N)	4.40	4.90	8.40	13.90	19.00	24.80	36.30	50.20	77.60	131.80
Max. load (N)	9.80	14.20	20.90	33.20	35.90	53.70	62.20	82.30	118.90	183.30

STROKES FOR COMPACT CYLINDERS

Standard stroke for single-acting cylinders	Standard stroke for other types	Max. recommended strokes for other types	Max. recommended strokes for non-rotating cylinders
Ø 12 → 10 mm	Ø 12; Ø 16 → from 5 to 40 mm	Ø 12÷Ø 25 → 200 mm	Ø 12÷Ø 63 → 120 mm
Ø 16; Ø 100 → 25 mm	Ø 20; Ø 25 → from 5 to 50 mm	Ø 32; Ø 40 → 300 mm	Ø 80; Ø 100 → 150 mm
	Ø 32÷Ø 100 → from 5 to 80 mm	Ø 50; Ø 63 → 400 mm	
		Ø 80; Ø 100 → 500 mm	

Max recommended strokes for through-rod perforated

Ø 20÷Ø 40 → from 5 to 80 mm
Ø 50; Ø 63 → from 5 to 100 mm
Ø 80; Ø 100 → from 5 to 160 mm

VALVE ASSEMBLY ON CYLINDER

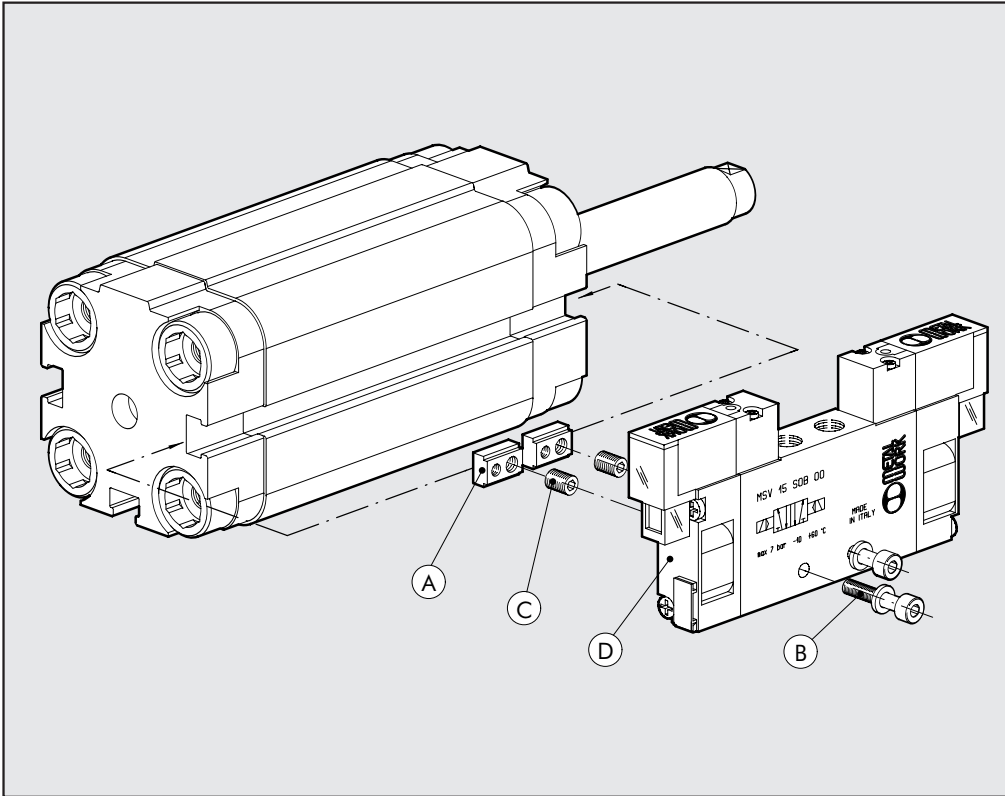

With this type of cylinder, the valves (D) can be mounted directly using the retracting sensor slot, without requiring the use of intermediate brackets. This can be done using the special plates (A) which come with both M3 and M4 threads, and screws (B) of the size, type and quantity shown in the table below.

The plates are supplied complete with 2 stud pins, one M3 and one M4 (C).

After the valve centre distance and the position of the valve have been determined, the plates can be secured to the cylinder. A "position memory" will be created to facilitate subsequent maintenance on the valve.

Type of valve to mount (D)	Fixing plate (A) cod. 0950003000	Position memory: grub screw (C) to be used	Screw (B) for connection to the cylinder (one per plate)	Washer (B) (one per screw)
MACH 11	n. 2	M4	M3x16 UNI 5931 (DIN 912)	A3.2 UNI 1751 (DIN 127A)
SERIE 70 1/8	n. 2	M3	M4x25 UNI 5931 (DIN 912)	—
SERIE 70 1/4	n. 2	M3	M4x30 UNI 5931 (DIN 912)	A4.3 UNI 1751 (DIN 127A)

MAXIMUM LOADS FOR NON-ROTATING VERSION

TRANSVERSAL FORCE FOR NON-ROTATING

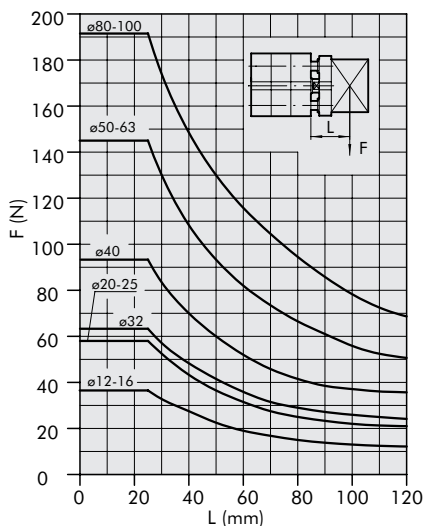

TRANSVERSAL FORCE FOR NON-ROTATING THROUGH-ROD

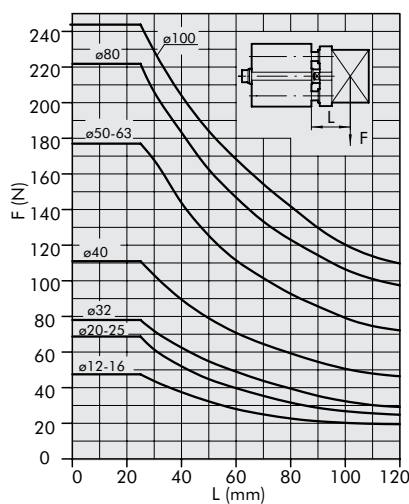

TORQUE DEPENDING ON STROKE

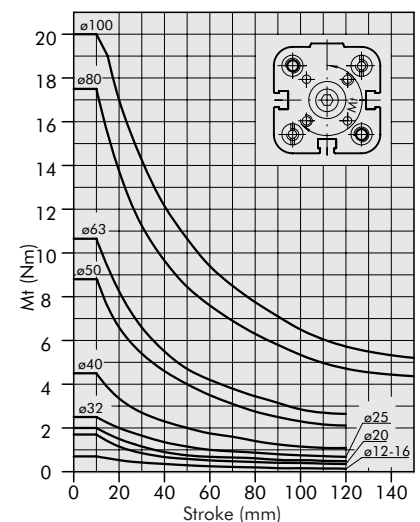

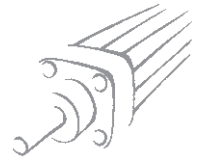

DIMENSIONS OF DOUBLE-ACTING Ø 12÷25 AND SINGLE-ACTING Ø 12÷25

+ = ADD THE STROKE
1 = SENSOR SLOT

230-240
233-243
234-244

	A	B	ØC	CH	CH1	D	ØEH9	F	G	H	H1	L	M	N	O	ØO1	P	Q	R	S	S1	NORMA
Ø 12	29	18	6	5	10	30	6	4	38	8	30	18.5	8	42.5	M4	3.2	M3	M5	M6	16	4.5	
Ø 16	29	18	8	7	13	30	6	4	38	8	30	18.5	10	42.5	M4	3.2	M4	M5	M8	20	4.5	
Ø 20	36.5	22	10	8	17	37.5	6	4	38	8	30	18.5	12	42.5	M5	4.2	M5	M5	M10x1.25	22	4.5	UNITOP
Ø 25	40.5	26	10	8	17	41.5	6	4	39.5	8	31.5	19	12	45	M5	4.2	M5	M5	M10x1.25	22	5.5	UNITOP

DIMENSIONS OF DOUBLE-ACTING Ø 32÷100 AND SINGLE-ACTING Ø 32÷100

+ = ADD THE STROKE
1 = SENSOR SLOT
7 = ONLY FOR Ø63÷100
8 = SEAT FOR DIN 7984 SCREWS

230-240
250-260
233-243
253-263
234-244
254-264

	A	B		ØC	CH	CH1	D	ØEH9	F	G	H	H1	L	M	N	O		ØO1		P	Q	R	S	S1	
		ISO	UNITOP													ISO	UNITOP								
Ø 32	47	32.5 ^{+0.4}	32 ^{+0.4}	-	12	10	17	48.5	6	4	44.5	7.5	37	4	14	50.5	M6	M6	5.2	5.2	M6	G1/8	M10x1.25	22	6
Ø 40	56	38	42	-	12	10	17	57.5	6	4	45.5	7.5	38	4.5	14	52	M6	M6	5.2	5.2	M6	G1/8	M10x1.25	22	6.5
Ø 50	67	46.5	50	-	16	13	19	69	6	4	45.5	7.5	38	4.5	16	53	M8	M8	6.2	6.2	M8	G1/8	M12x1.25	24	7.5
Ø 63	80	56.5	62	13	16	13	19	82	8	4	50	7.5	42.5	5.5	16	57.5	M8	M10	6.2	8.5	M8	G1/8	M12x1.25	24	7.5
Ø 80	102	72	82	17	20	17	24	105	8	4	56	8.5	47.5	5.5	20	64	M10	M10	8.5	8.5	M10	G1/8	M16x1.5	32	8
Ø 100	123	89	103	21	25	22	30	126	8	4	66.5	10.5	56	5.5	24	76.5	M10	M10	8.5	8.5	M12	G1/4	M20x1.5	40	10

DIMENSIONS OF NON-ROTATING Ø 12 ÷ 25

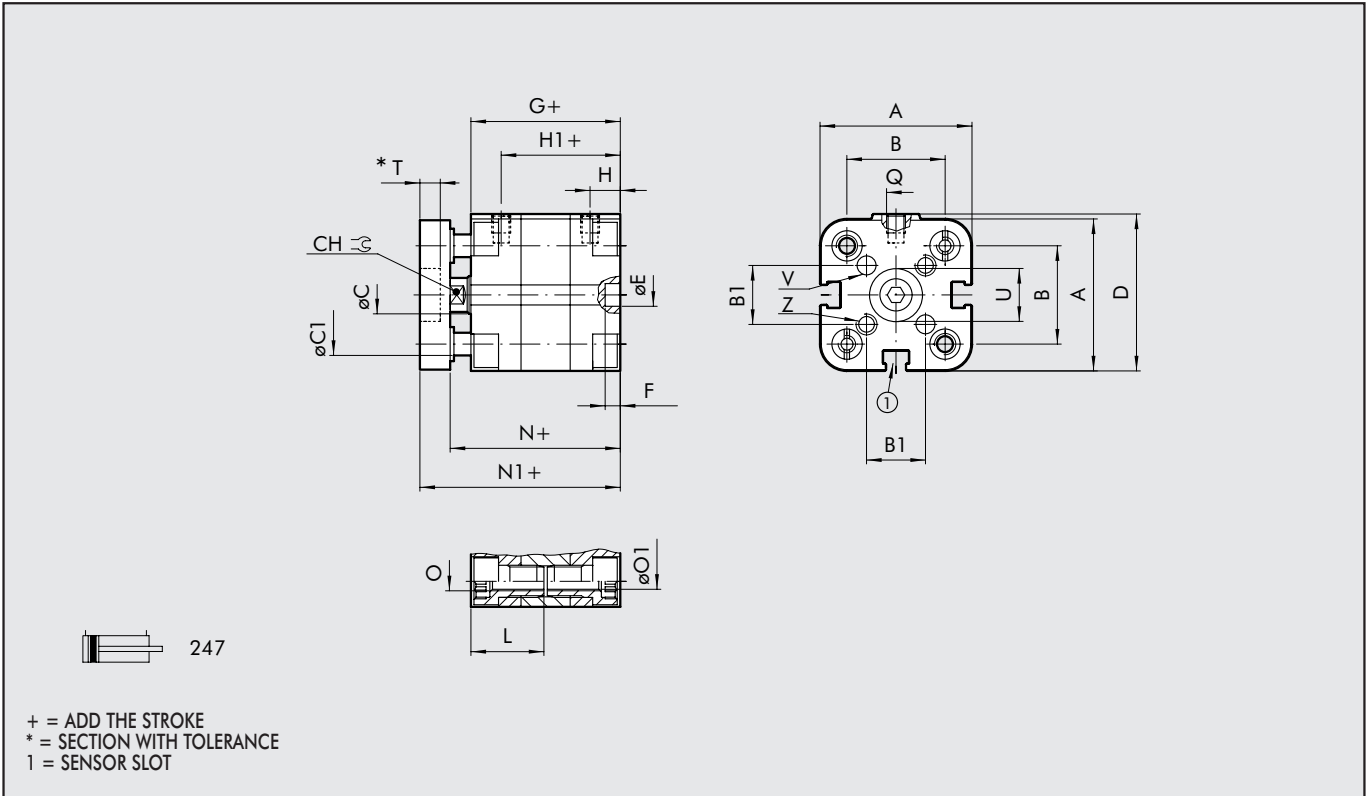

NON-ROTATING FEMALE THROUGH-ROD

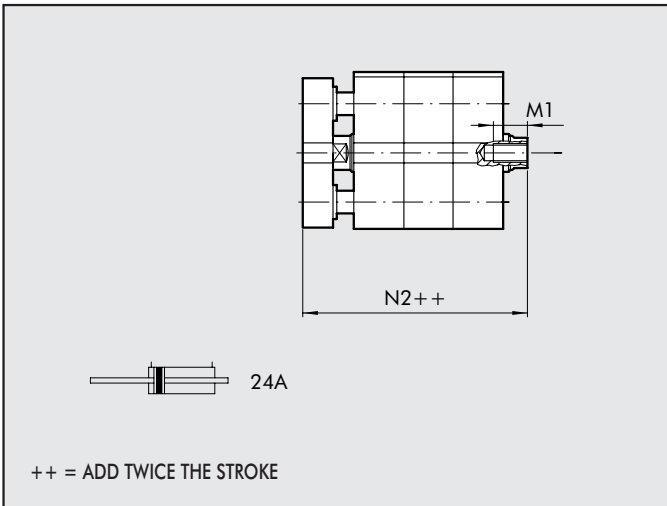

NON-ROTATING MALE THROUGH-ROD

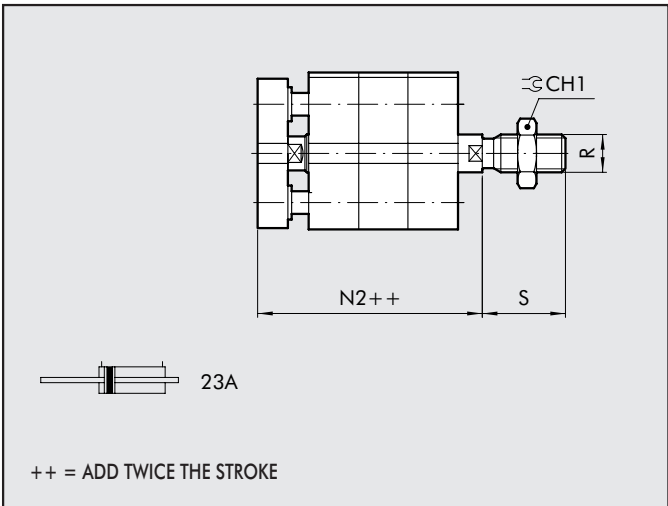

	A	B	B1	ØC	ØC1	CH	CH1	D	ØE H9	F	G	H	H1	L	M1 x strokes		N	N1	N2
															<5	≥5			
Ø 12	29	18	9.9	6	5	5	10	30	6	4	38	8	30	18.5	5	8	42.5	48.5	53
Ø 16	29	18	9.9	8	5	7	13	30	6	4	38	8	30	18.5	5	10	42.5	48.5	53
Ø 20	36.5	22	12	10	6	8	17	37.5	6	4	38	8	30	18.5	7	12	42.5	50.5	55
Ø 25	40.5	26	15.6	10	6	8	17	41.5	6	4	39.5	8	31.5	19	7	12	45	53	58.5

	O	ØO1	P	Q	R	S	T	ØU H9	ØV H8	Z	STANDARD
Ø 12	M4	3.2	M3	M5	M6	16	2	6	3	M3	
Ø 16	M4	3.2	M4	M5	M8	20	2	8	3	M3	
Ø 20	M5	4.2	M5	M5	M10x1.25	22	3.5	10	4	M4	UNITOP
Ø 25	M5	4.2	M5	M5	M10x1.25	22	4	14	5	M5	UNITOP

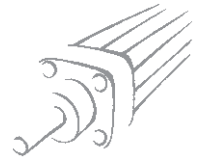

DIMENSIONS OF NON-ROTATING Ø 32 ÷ 100

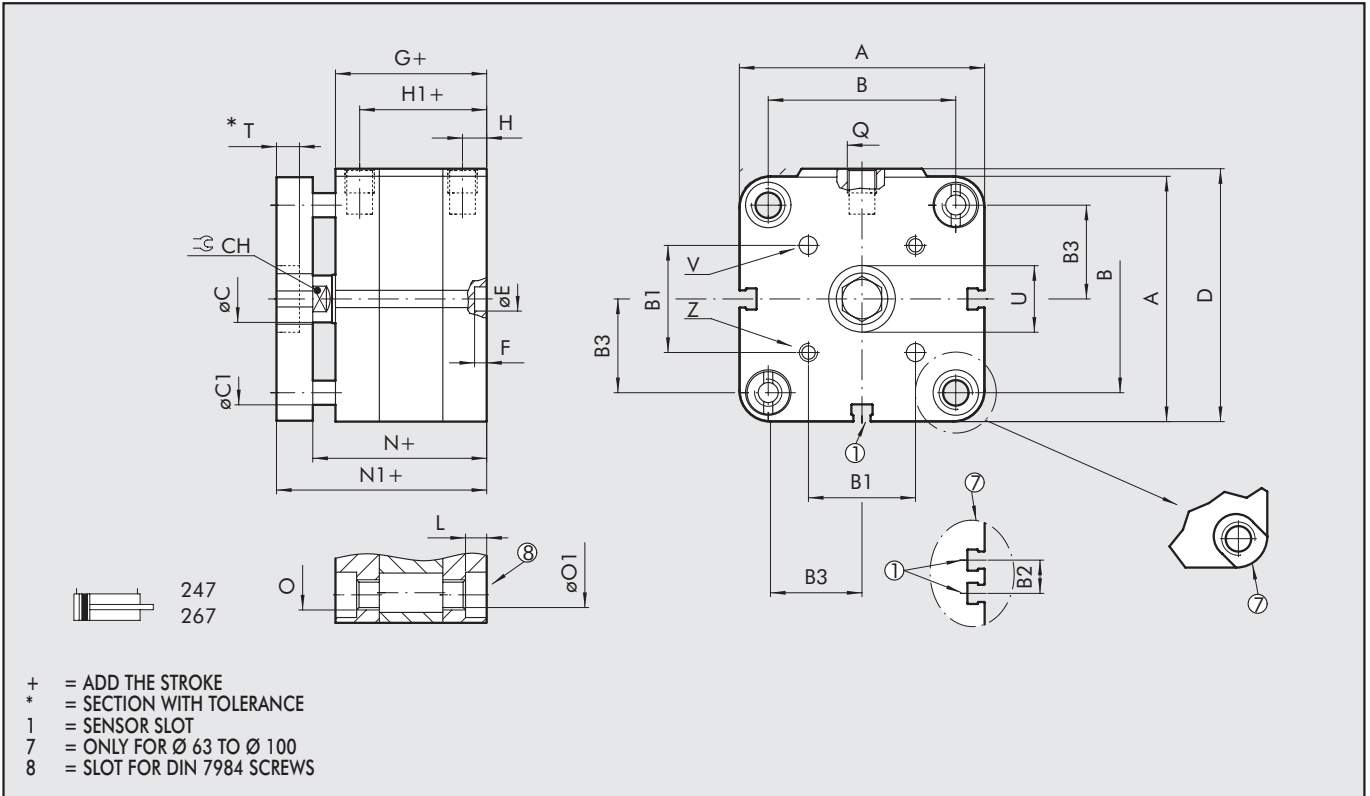

NON-ROTATING FEMALE THROUGH-ROD

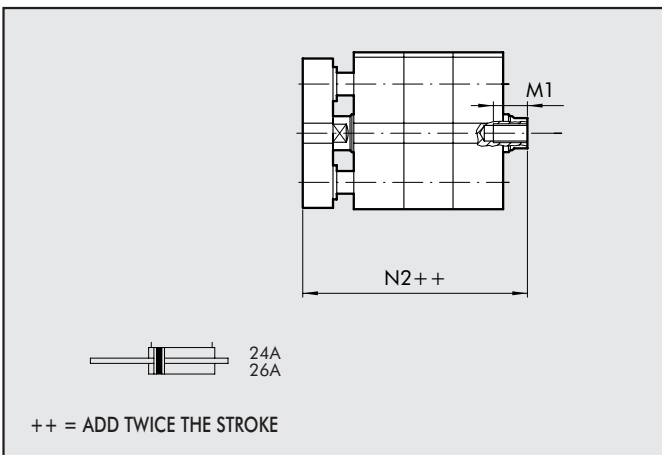

NON-ROTATING MALE THROUGH-ROD

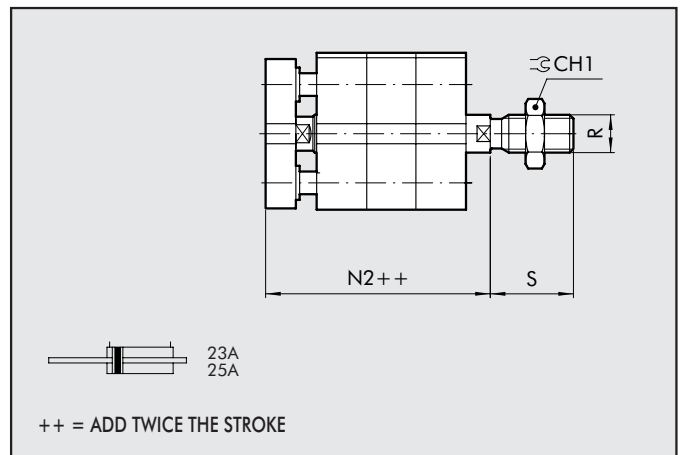

	B		B1	B2	B3	ØC	ØC1	CH	CH1	D	ØEH9	F	G	H	H1	L	M1 x strokes		
	A	ISO															UNITOP	≥5	<5
Ø 32	47	32.5 ^{+0.1}	32 ^{+0.1}	19.8	-	16.1	12	8	10	17	48.5	6	4	44.5	7.5	37	4	14	9
Ø 40	56	38	42	23.3	-	20	12	8	10	17	57.5	6	4	45.5	7.5	38	4.5	14	9
Ø 50	67	46.5	50	29.7	-	24	16	10	13	19	69	6	4	45.5	7.5	38	4.5	16	11
Ø 63	80	56.5	62	35.4	13	30	16	10	13	19	82	8	4	50	7.5	42.5	5.5	16	11
Ø 80	102	72	82	46	17	38.5	20	12	17	24	105	8	4	56	8.5	47.5	5.5	20	15
Ø 100	123	89	103	56.6	21	48	25	12	22	30	126	8	4	66.5	10.5	56	5.5	24	19
	O			ØO1				P	Q	R	S	T	ØUH9	ØVH8	Z				
	N	N1	N2	ISO	UNITOP	ISO	UNITOP												
Ø 32	50.5	60.5	66.5	M6	M6	5.2	5.2	M6	G1/8	M10x1.25	22	4.5	17	5	M5				
Ø 40	52	62	68.5	M6	M6	5.2	5.2	M6	G1/8	M10x1.25	22	4.5	17	5	M5				
Ø 50	53	65	72.5	M8	M8	6.2	6.2	M8	G1/8	M12x1.25	24	6	22	6	M6				
Ø 63	57.5	69.5	77	M8	M10	6.2	8.5	M8	G1/8	M12x1.25	24	6	22	6	M6				
Ø 80	64	78	86	M10	M10	8.5	8.5	M10	G1/8	M16x1.5	32	8	28	8	M8				
Ø 100	76.5	90.5	100.5	M10	M10	8.5	8.5	M12	G1/4	M20x1.5	40	9	30	10	M10				

DIMENSIONS OF THROUGH-ROD Ø 12÷25

SE-DE MALE PERFORATED THROUGH-ROD

+ = ADD THE STROKE
++ = ADD TWICE THE STROKE
1 = SENSOR SLOT

	A	B	ØC	CH	CH1	D	G	H	H1	L	M	M1xstrokes		N	N2	O	ØO1	P	P1	P2	Q	R	S
												<5	≥5										
Ø 12	29	18	6	5	10	30	38	8	30	18.5	8	5	8	42.5	47	M4	3.2	M3	-	-	M5	M6	16
Ø 16	29	18	8	7	13	30	38	8	30	18.5	10	5	10	42.5	47	M4	3.2	M4	-	-	M5	M8	20
Ø 20*	36.5	22	10	8	17	37.5	38	8	30	18.5	12	7	12	42.5	47	M5	4.2	M5	-	1.5	M5	M10x1.25	22
Ø 25*	40.5	26	10	8	17	41.5	39.5	8	31.5	19	12	7	12	45	50.5	M5	4.2	M5	-	1.5	M5	M10x1.25	22

*Built to UNITOP

DIMENSIONS OF THROUGH-ROD Ø 32÷100

SE-DE MALE PERFORATED THROUGH-ROD

+ = ADD THE STROKE
++ = ADD TWICE THE STROKE
1 = SENSOR SLOT
7 = ONLY FOR Ø 63 TO Ø 100
8 = SLOT FOR DIN 7984 SCREWS

	A	B		ØC	CH	CH1	D	G	H	H1	L	M	M1xstrokes		N	N2	O		ØO1		P	P1	P2	Q	R	S	
		ISO	UNITOP										ISO	UNITOP			ISO	UNITOP									
Ø 32	47	32.5±0.4	32±0.4	-	12	10	17	48.5	44.5	7.5	37	4	14	14	9	50.5	56.5	M6	M6	5.2	5.2	M6	-	2.5	G1/8	M10x1.25	22
Ø 40	56	38	42	-	12	10	17	57.5	45.5	7.5	38	4.5	14	14	9	52	58.5	M6	M6	5.2	5.2	M6	-	2.5	G1/8	M10x1.25	22
Ø 50	67	46.5	50	-	16	13	19	69	45.5	7.5	38	4.5	16	16	11	53	60.5	M8	M8	6.2	6.2	M8	-	4	G1/8	M12x1.25	24
Ø 63	80	56.5	62	13	16	13	19	82	50	7.5	42	5.5	16	16	11	57.5	65	M8	M10	6.2	8.5	M8	-	4	G1/8	M12x1.25	24
Ø 80	102	72	82	17	20	17	24	105	56	8.5	47.5	5.5	20	20	15	64	72	M10	M10	8.5	8.5	M10	1/8	5	G1/8	M16x1.5	32
Ø 100	123	89	103	21	25	22	30	126	66.5	10.5	56	5.5	24	24	19	76.5	86.5	M10	M10	8.5	8.5	M12	1/4	6	G1/4	M20x1.5	40

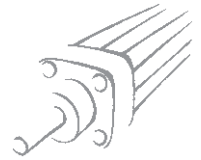

DIMENSIONS OF TANDEM Ø 20÷25 - 4-STAGES

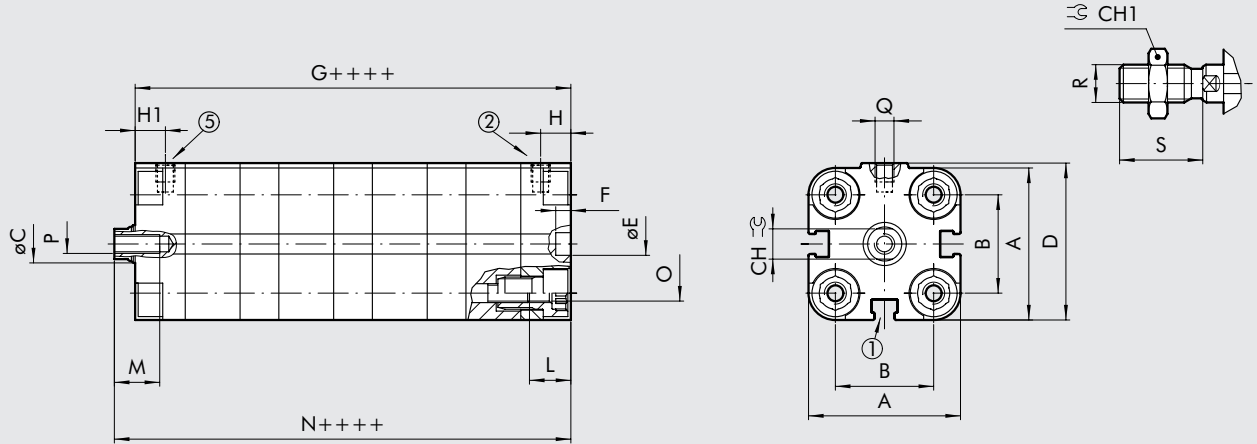

++++ = ADD FOUR TIMES THE STROKE
 1 = SENSOR SLOT
 2 = CYLINDERS OUT
 5 = CYLINDERS IN

TANDEM 3 STAGES

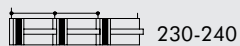
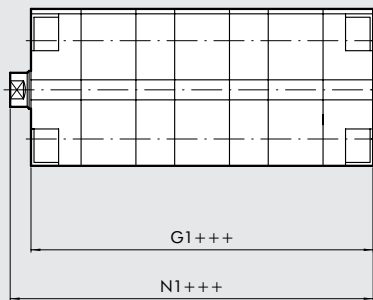

+++ = ADD THREE TIMES THE STROKE

TANDEM 2 STAGES

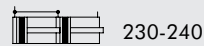
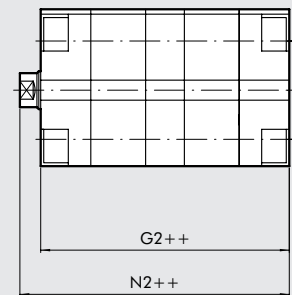

++ = ADD TWICE THE STROKE

	A	B	ØC	CH	CH1	D	ØEH9	F	G	G1	G2	H	H1	L	M	N	N1
Ø 20	36.5	22	10	8	17	37.5	6	4	114.5	89	63.5	8	8	10	12	119	93.5
Ø 25	40.5	26	10	8	17	41.5	6	4	118	92	66	8	8	10	12	123.5	97.5

N2	O	P	Q	R	S	Standard
68	M5	M5	M5	M10x1.25	22	UNITOP
71.5	M5	M5	M5	M10x1.25	22	UNITOP

DIMENSIONS OF TANDEM Ø 32 ÷ 100 - 4-STAGES

2 = CYLINDERS OUT FOR Ø 32÷63
 5 = CYLINDERS IN FOR Ø 32÷63
 6 = CYLINDERS IN FOR Ø 80; 100
 9 = CYLINDERS OUT FOR Ø 80; 100
 1 = SENSOR SLOT
 7 = ONLY FOR Ø 63÷100
 8 = SLOT FOR DIN 7984 SCREWS

230-240
 250-260

+ + + + = ADD FOUR TIMES THE STROKE

TANDEM 3-STAGES

230-240
 250-260

+ + + = ADD THREE TIMES THE STROKE

TANDEM 2-STAGES

230-240
 250-260

+ + = ADD TWICE THE STROKE

	B		B2	ØC	CH	CH1	D	ØE H9	F	G	G1	G2	H	H1	K	K1	
	A	ISO UNITOP															
Ø 32	47	32.5 ^{+0.1} _{-0.4}	32 ^{+0.4} _{-0.1}	-	12	10	17	48.5	6	4	154	117.5	81	7.5	7.5	-	-
Ø 40	56	38	42	-	12	10	17	57.5	6	4	162.5	123.5	84.5	7.5	7.5	-	-
Ø 50	67	46.5	50	-	16	13	19	69	6	4	163.5	124	85	7.5	7.5	-	-
Ø 63	80	56.5	62	13	16	13	19	82	8	4	182	138	94	7.5	7.5	-	-
Ø 80	102	72	82	17	20	17	24	105	8	4	204.5	155	105.5	8.5	-	10.5	10.5
Ø 100	123	89	103	21	25	22	30	126	8	4	243	184	125.5	10.5	-	14.5	14.5

	O		ØO1		P	Q	R	S
	L	M	ISO	UNITOP				
Ø 32	4	14	M6	M6	5.2	G1/8	M10x1.25	22
Ø 40	4.5	14	M6	M6	5.2	G1/8	M10x1.25	22
Ø 50	4.5	16	M8	M8	6.2	G1/8	M12x1.25	24
Ø 63	5.5	16	M8	M10	6.2	G1/8	M12x1.25	24
Ø 80	5.5	20	M10	M10	8.5	G1/8	M16x1.5	32
Ø 100	5.5	24	M10	M10	8.5	G1/4	M20x1.5	40

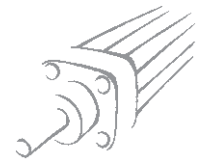

DIMENSIONS OF MULTI-POSITION Ø 12÷25 - 3-STAGES

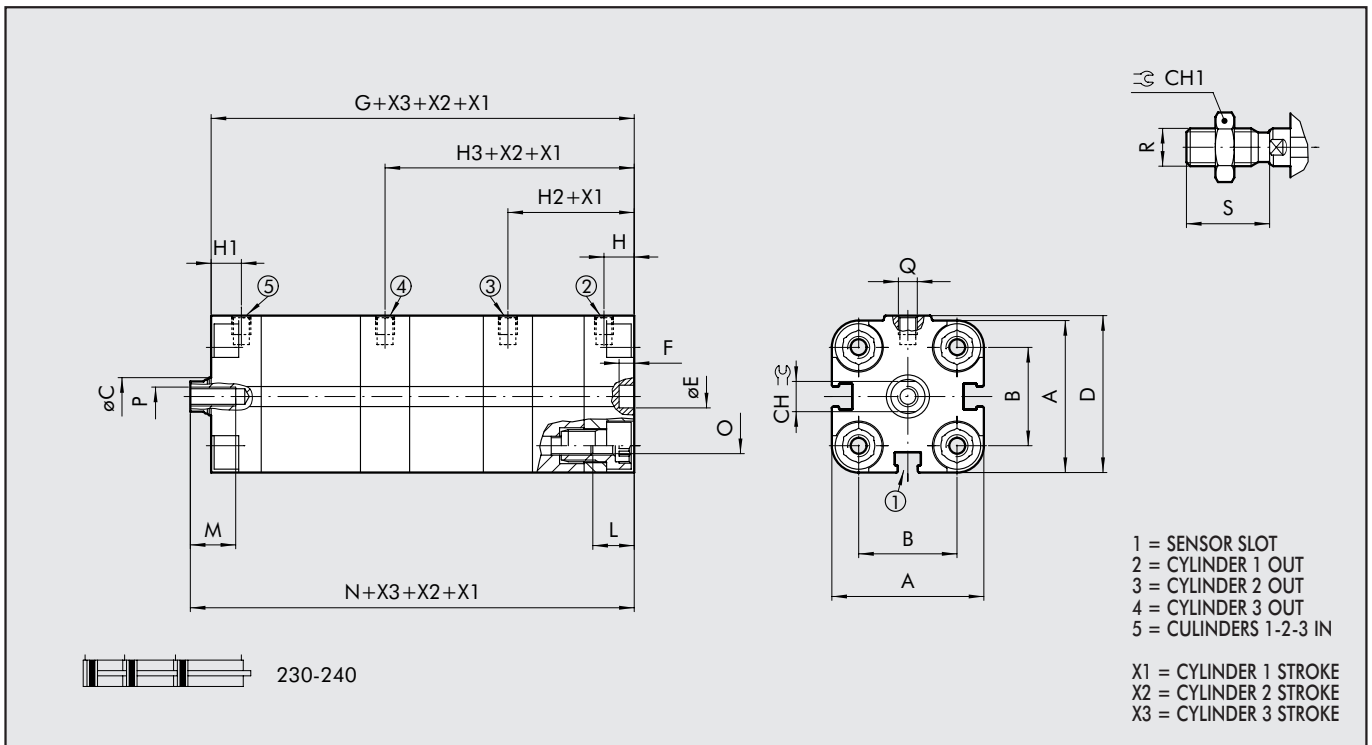

MULTI-POSITION 2-STAGES

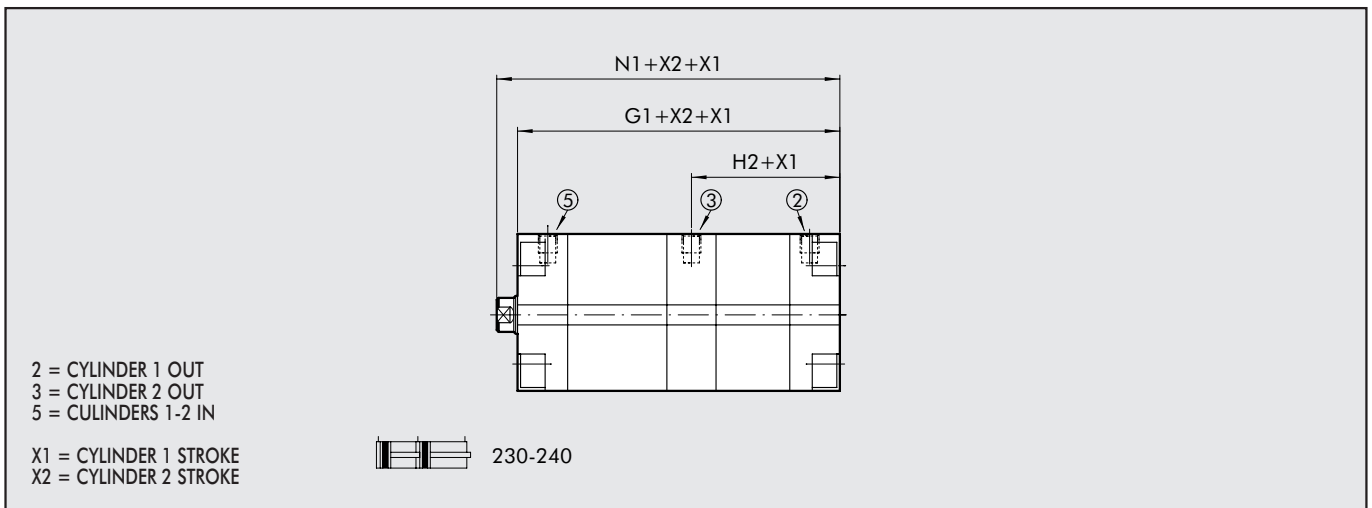

	A	B	ØC	CH	CH1	D	ØEH9	F	G	G1	H	H1	H2	H3	L	M	N	N1	O	P	Q	R	S
Ø 12	29	18	6	5	10	30	6	4	89	63.5	8	8	33.5	59	10	8	93.5	68	M4	M3	M5	M6	16
Ø 16	29	18	8	7	13	30	6	4	89	63.5	8	8	33.5	59	10	10	93.5	68	M4	M4	M5	M8	20
Ø 20*	36.5	22	10	8	17	37.5	6	4	89	63.5	8	8	33.5	59	10	12	93.5	68	M5	M5	M5	M10x1.25	22
Ø 25*	40.5	26	10	8	17	41.5	6	4	92	66	8	8	34	60	10	12	97.5	71.5	M5	M5	M5	M10x1.25	22

*Standard UNITOP

DIMENSIONS OF MULTI-POSITION Ø 32 ÷ 100 - 3-STAGES

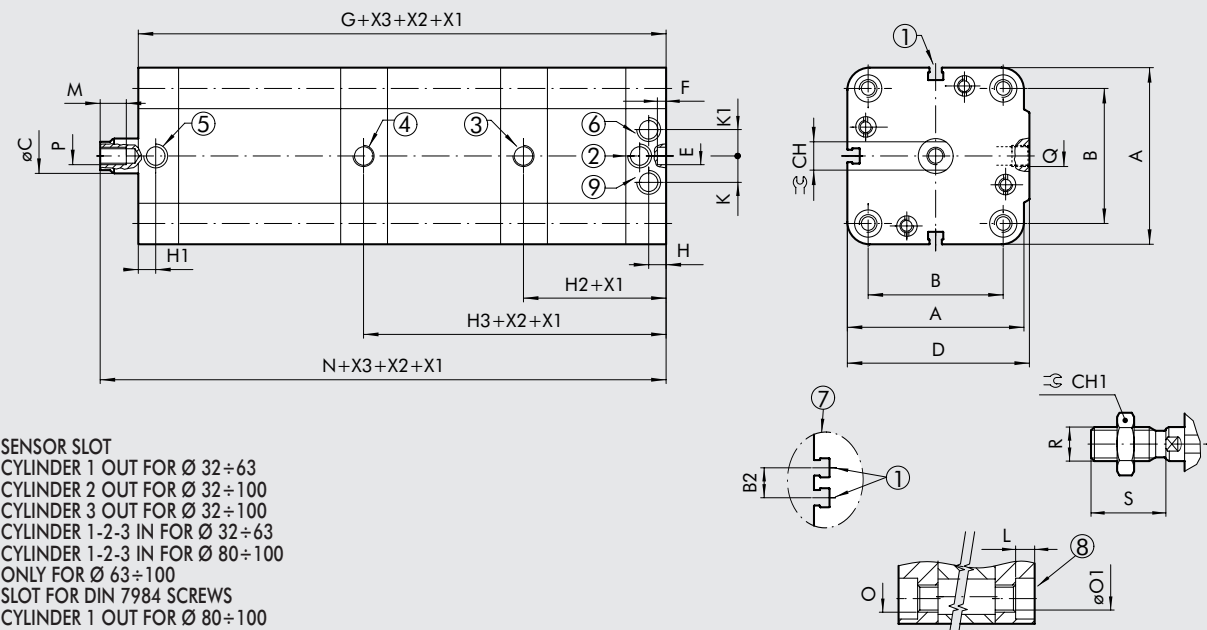

1 = SENSOR SLOT
 2 = CYLINDER 1 OUT FOR Ø 32 ÷ 63
 3 = CYLINDER 2 OUT FOR Ø 32 ÷ 100
 4 = CYLINDER 3 OUT FOR Ø 32 ÷ 100
 5 = CYLINDER 1-2-3 IN FOR Ø 32 ÷ 63
 6 = CYLINDER 1-2-3 IN FOR Ø 80 ÷ 100
 7 = ONLY FOR Ø 63 ÷ 100
 8 = SLOT FOR DIN 7984 SCREWS
 9 = CYLINDER 1 OUT FOR Ø 80 ÷ 100

X1 = CYLINDER 1 STROKE
 X2 = CYLINDER 2 STROKE
 X3 = CYLINDER 3 STROKE

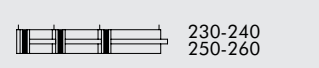

230-240
250-260

MULTI-POSITION 2-STAGES

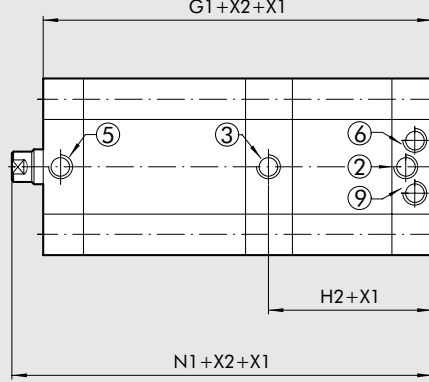

2 = CYLINDER 1 OUT FOR Ø 32 ÷ 63
 3 = CYLINDER 2 OUT FOR Ø 32 ÷ 100
 5 = CYLINDER 1-2 IN FOR Ø 32 ÷ 63
 6 = CYLINDER 1-2 IN FOR Ø 80 ÷ 100
 9 = CYLINDER 1 OUT FOR Ø 80 ÷ 100

X1 = CYLINDER 1 STROKE
 X2 = CYLINDER 2 STROKE



230-240
250-260

	A	B		B2	ØC	CH	CH1	D	ØE H9	F	G	G1	H	H1	H2	H3
		ISO	UNITOP													
Ø 32	47	32.5 ^{+0.1} _{-0.4}	32 ^{+0.1}	-	12	10	17	48.5	6	4	117.5	81	7.5	7.5	44	80.5
Ø 40	56	38	42	-	12	10	17	57.5	6	4	123.5	84.5	7.5	7.5	46.5	85.5
Ø 50	67	46.5	50	-	16	13	19	69	6	4	124	85	7.5	7.5	47	86
Ø 63	80	56.5	62	13	16	13	19	82	8	4	138	94	7.5	7.5	51.5	95.5
Ø 80	102	72	82	17	20	17	24	105	8	4	155	105.5	8.5	-	58	107.5
Ø 100	123	89	103	21	25	22	30	126	8	4	184	125.5	10.5	-	69.3	128
	K	K1	L	M	N	N1	O		ØO1		P	Q	R	S		
							ISO	UNITOP	ISO	UNITOP						
Ø 32	-	-	4	14	123.5	87	M6	M6	5.2	5.2	M6	G1/8	M10x1.25	22		
Ø 40	-	-	4.5	14	130	91	M6	M6	5.2	5.2	M6	G1/8	M10x1.25	22		
Ø 50	-	-	4.5	16	131.5	92.5	M8	M8	6.2	6.2	M8	G1/8	M12x1.25	24		
Ø 63	-	-	5.5	16	145.5	101.5	M8	M10	6.2	8.5	M8	G1/8	M12x1.25	24		
Ø 80	10.5	10.5	5.5	20	163	113.5	M10	M10	8.5	8.5	M10	G1/8	M16x1.5	32		
Ø 100	14.5	14.5	5.5	24	194	135.5	M10	M10	8.5	8.5	M12	G1/4	M20x1.5	40		



FUNCTIONAL DIAGRAMS

LEGENDA

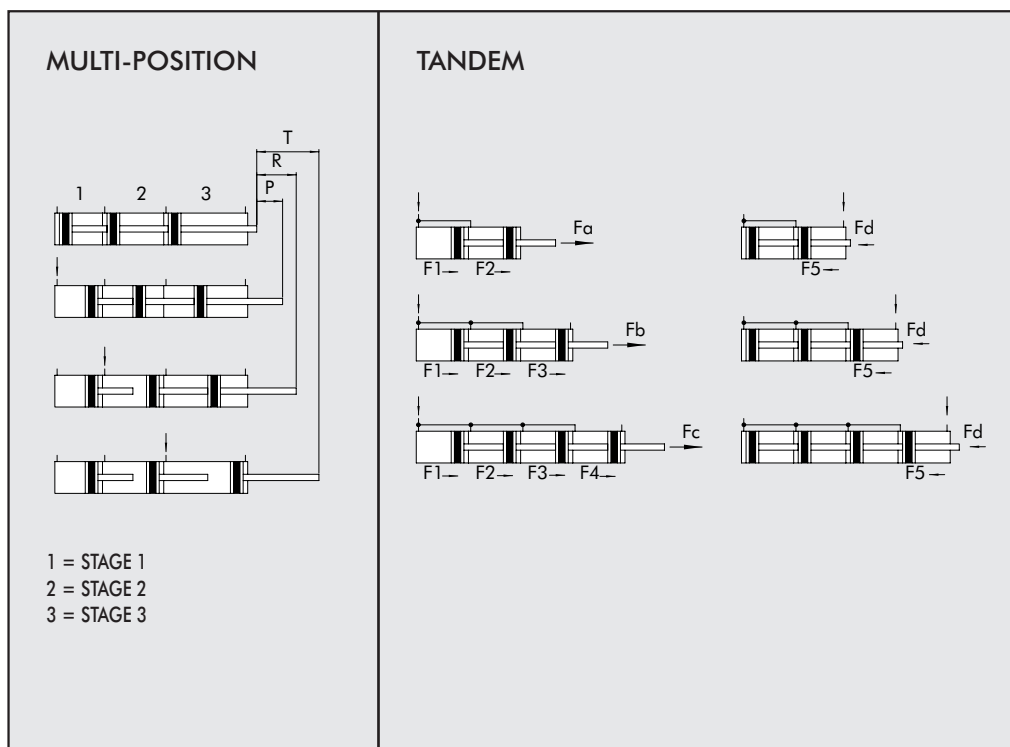

P = Stage 1 stroke
R = Stage 2 stroke
T = Stage 3 stroke

$F_a = F_1 + F_2$ [N]
 $F_b = F_1 + F_2 + F_3$ [N]
 $F_c = F_1 + F_2 + F_3 + F_4$ [N]
 $F_d = F_5$ [N]

KEY TO CODE FOR COMPACT CYLINDER SERIES "CMPC"

CYL	2	3	1	0	2 5	0	0 5 0	X	P			
	TYPE			BORE		STROKE		CONFIGURATION				
23	Compact cylinder centre distances to UNITOP male piston rod	0	Double-acting through-rod	0	Magnetic	12	0	Standard	*C	C45 piston rod	P	Polyurethane gaskets
		1	Double-acting through-rod	S	Non-magnetic	16	+A	2-stage tandem		Chromium-plated		
		2 +	Double-acting through-rod perforated	▲G	No stick slip	20	+B	3-stage tandem		Stainless steel piston rod		
24	Compact cylinder centre distances to UNITOP female piston rod	3 ●	Single-acting retracting piston rod			25	+C	4-stage tandem				
		4 ●	Single-acting extended piston rod			32						
25	Compact cylinder centre distances to ISO male piston rod	5 ●	Single-acting through-rod			40						
		6 ● +	Single-acting through piston rod perforated			50						
26	Compact cylinder centre distances to ISO female piston rod	7 ▼	Double-acting non-rotating			63						
		A	Double-acting through-rod non-rotating			80	P	Stage 1				
						100	R	Stage 2				
							T	Stage 3				

◆ In the code of cylinder with letter in fourth position Ø 100 becomes A1

■ Codes only for cylinders Ø 32 ÷ 100

● Can also be used as double-acting with spring return

▼ For versions 24 and 26 only (female piston rod)

+ Available from Ø 20

▲ Standard for ø12 ÷ 25

* Available from Ø 32

Examples of codes – the ordering codes for a Multi-position cylinder is a combination of several codes, each describing a stage.

Multi-position cylinder:

Stage 1: CIL 240 0 25 P ... XP

Stage 2: CIL 240 0 25 R ... XP

Stage 3: CIL 240 0 25 T ... XP

FOOT - MODEL A

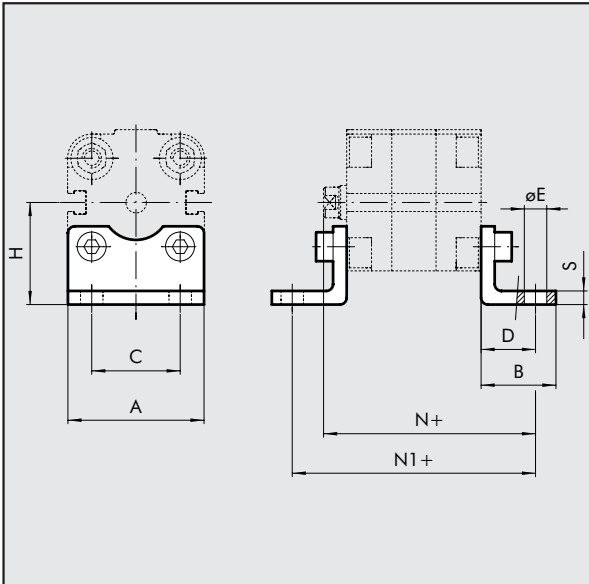

UNITOP Codes	Ø	A	B	C	D	ØE	H	N	N1	S	Weight [g]
▲ W0950126001	12	30	17.5	18	13	5.5	22	55.5	64	3	26
▲ W0950126001	16	30	17.5	18	13	5.5	22	55.5	64	3	26
W0950206001	20	36	22	22	16	6.6	27	58.5	70	4	46
W0950256001	25	40	22	26	16	6.6	30	58.5	70	4	52
W0950322001	32	45	35	32	24	7	31.9	74.5	92.5	4	76
W0950406001	40	60	28	42	20	9	42.5	72	85.5	5	88
W0950506001	50	68	32	50	24	9	47	77	93.5	6	176
W0950636001	63	84	39	62	27	11	59.5	84.5	104	6	276
W0950806001	80	102	42	82	30	11	65.5	94	116	8	392
W0951006001	100	123	45	103	33	13.5	78	109.5	132.5	8	558

ISO Codes	Ø	A	B	C	D	ØE	H	N	N1	S	Weight [g]
W0950322001	32	45	35	32	24	7	31.9	74.5	92.5	4	76
W0950402001	40	52	43	36	28	9	36	80	101.5	4	100
W0950502001	50	65	47	45	32	9	45	85	109.5	4	162
W0950632001	63	75	47	50	32	9	50	89.5	114	6	266
W0950802001	80	95	61	63	41	12	63	105	138	6	456
W0951002001	100	115	65	75	41	14	71	117.5	148.5	6	572

▲ Non UNITOP norm fixing distance
 Note: Individually packed with 2 screws.

FEMALE HINGE-MODEL B

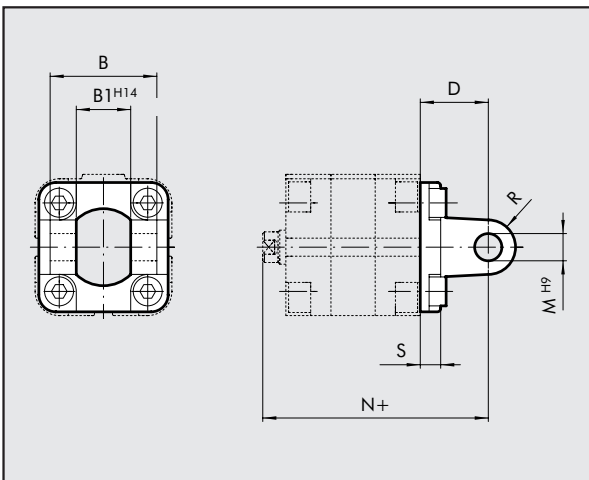

UNITOP Codes	Ø	B	B1	D	M	N	R	S	Weight [g]
W0950322003	32	45	26	22	10	72.5	11	10	116
W0950406003	40	52	28	25	12	77	12.5	9	184
W0950506003	50	60	32	27	12	80	12.5	11	266
W0950636003	63	70	40	32	16	89.5	15	11	470
W0950806003	80	90	50	36	16	100	15	13	670
W0951006003	100	110	60	41	20	117.5	20	15	1110

ISO Codes	Ø	B	B1	D	M	N	R	S	Weight [g]
W0950322003	32	45	26	22	10	72.5	11	10	74
W0950402003	40	52	28	25	12	77	13	10	116
W0950502003	50	60	32	27	12	80	13	12	176
W0950632003	63	70	40	32	16	89.5	17	12	468
W0950802003	80	90	50	36	16	100	17	16	536
W0951002003	100	110	60	41	20	117.5	21	16	925

Note: Supplied with 4 screws, 4 washers, 2 snap-rings and 1 pin.

MALE HINGE-MODEL BA

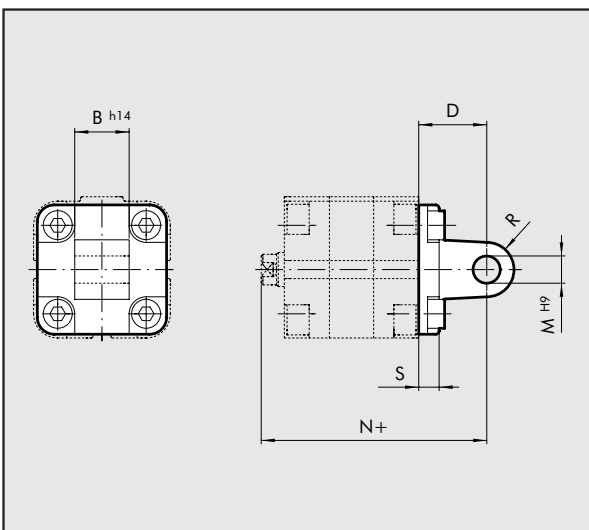

UNITOP Codes	Ø	B	D	M	N	R	S	Weight [g]
▲ W0950126004	12	12	16	6	58.5	6	6	24
▲ W0950126004	16	12	16	6	58.5	6	6	24
W0950206004	20	16	20	8	62.5	8	6	44
W0950256004	25	16	20	8	62.5	8	6	48

ISO Codes	Ø	B	D	M	N	R	S	Weight [g]
W0950322004	32	26	22	10	72.5	11	10	94
W0950402004	40	28	25	12	77	13	10	124
W0950502004	50	32	27	12	80	13	12	220
W0950632004	63	40	32	16	89.5	17	12	316
W0950802004	80	50	36	16	100	17	16	578
W0951002004	100	60	41	20	117.5	21	16	850

▲ Non UNITOP norm fixing distance

Note: Supplied with 4 screws, 4 washers



FLANGE Ø 12÷25 - MODEL C

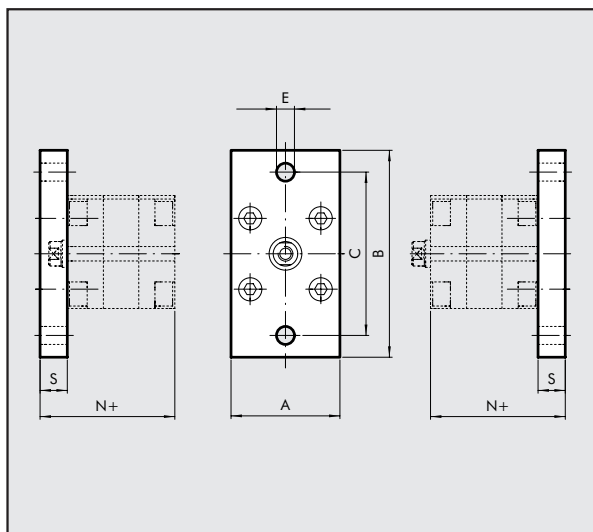

Codes	Ø	A	B	C	E	N	S	Weight [g]
▲ W0950126002	12	29	55	43	5.5	48	10	112
▲ W0950126002	16	29	55	43	5.5	48	10	112
W0950206002	20	36	70	55	6.6	48	10	184
W0950256002	25	40	76	60	6.6	49.5	10	226

▲ Non UNITOP norm fixing distance

Note: Supplied with 4 screws.

FLANGE Ø 32÷100 - MODEL C

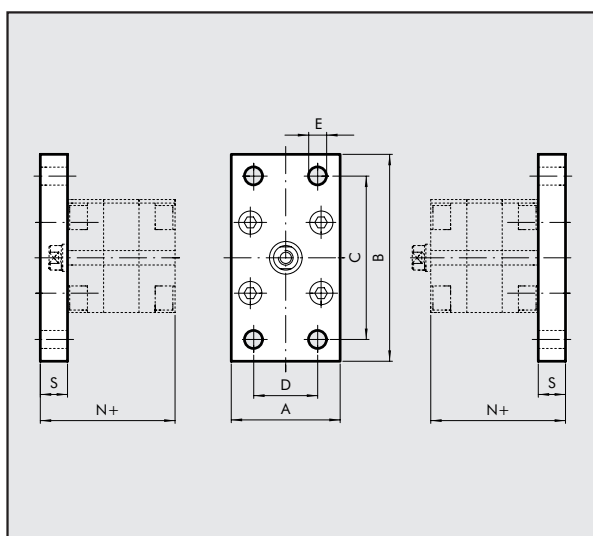

UNITOP Codes	Ø	A	B	C	D	E	N	S	Weight [g]
W0950322002	32	50	80	64	32	7	54.5	10	246
W0950406002	40	60	102	82	36	9	55.5	10	454
W0950506002	50	68	110	90	45	9	57.5	12	655
W0950636002	63	87	130	110	50	9	65	15	1255
W0950806002	80	107	160	135	63	12	71	15	1900
W0951006002	100	128	190	163	75	14	81.5	15	2700

ISO Codes	Ø	A	B	C	D	E	N	S	Weight [g]
W0950322002	32	50	80	64	32	7	54.5	10	246
W0950402002	40	55	90	72	36	9	55.5	10	290
W0950502002	50	65	110	90	45	9	57.5	12	522
W0950632002	63	75	120	100	50	9	62	12	670
W0950802002	80	95	153	126	63	12	72	16	1420
W0951002002	100	115	178	150	75	14	82.5	16	2040

Note: Supplied with 4 screws.

ARTICULATED MALE HINGE - MODEL BAS

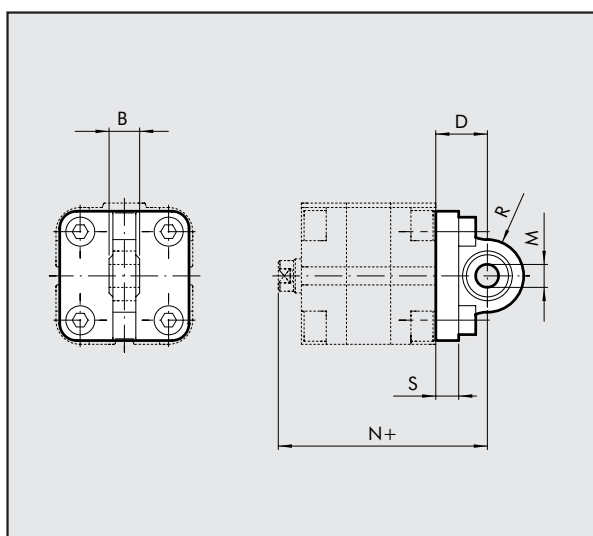

ISO Codes	Ø	B	D	M	N	R	S	Weight [g]
W0950322006	32	14	22	10	72.5	16	10	106
W0950402006	40	16	25	12	77	19	10	142
W0950502006	50	16	27	12	80	19	12	236
W0950632006	63	21	32	16	89.5	24	12	336
W0950802006	80	21	36	16	100	24	16	572
W0951002006	100	25	41	20	117.5	30	16	840

Note: Supplied with 4 screws, 4 washers.

FLANGE FOR OPPOSED CYLINDERS

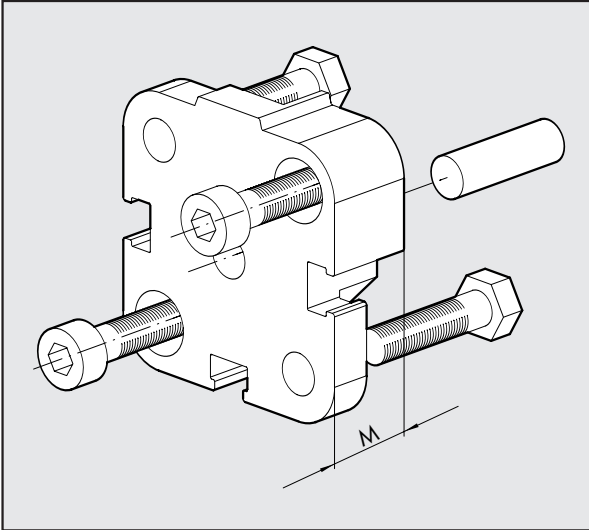

UNITOP Codes	ISO Codes	Ø	M	Weight [g]	
				UNITOP	ISO
▲ 0950123060	-	12	12.5	29	-
▲ 0950123060	-	16	12.5	29	-
0950203060	-	20	12.5	45	-
0950253060	-	25	13	57	-
0950323060	0950323060	32	14.5	88	88
0950403060	0950403061	40	14.5	106	106
0950503060	0950503061	50	14.5	172	158
0950633060	0950633061	63	14.5	274	258
0950803060	0950803061	80	16.5	470	452
0951003060	0951003061	100	19.5	826	801

▲ Non UNITOP norm fixing distance

Note: Supplied complete with 1 pin, 4 screws.

ASSEMBLING OPPOSING CYLINDERS

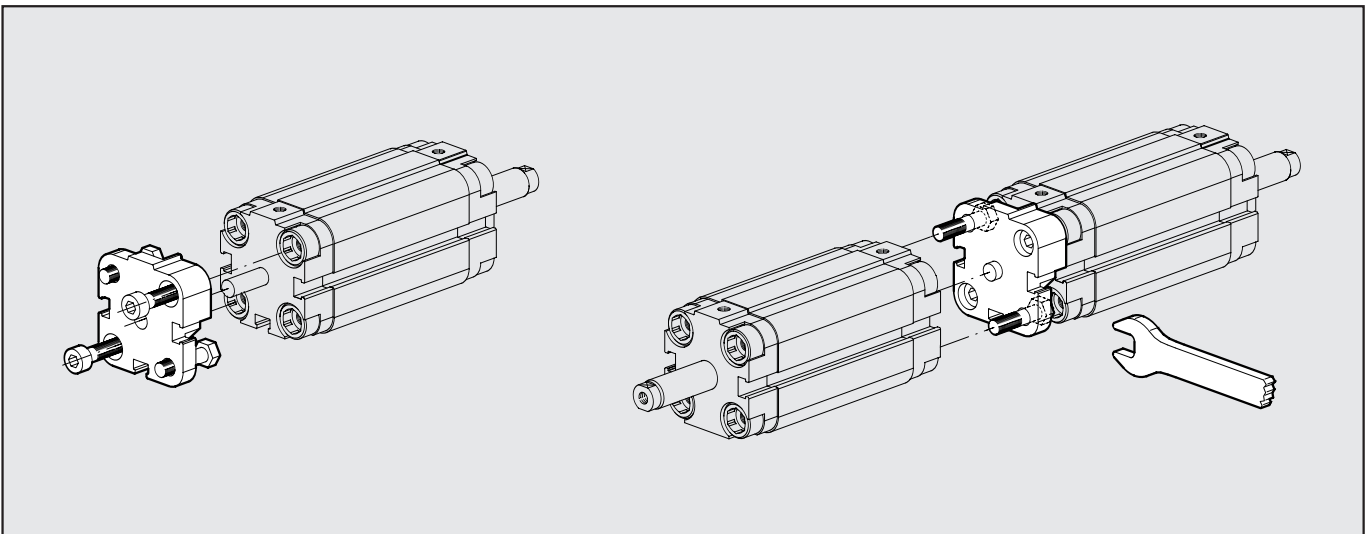

FORK - MODEL GK-M

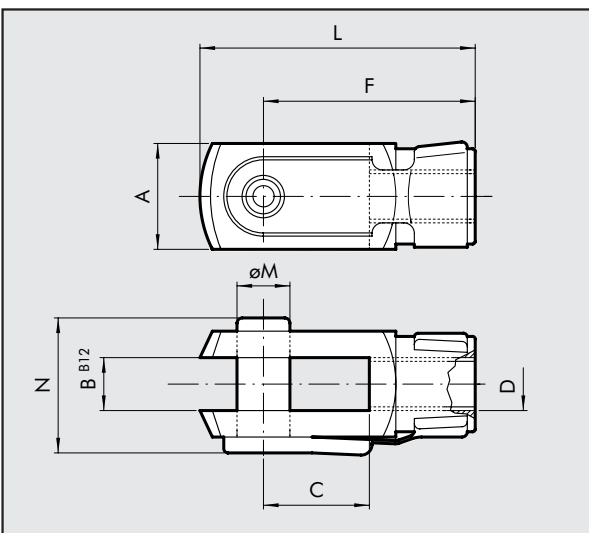

UNITOP-ISO Codes	Ø	A	B	C	D	F	L	ØM	N	Weight [g]
W0950120020	12	12	6	12	M6	24	31	6	16	20
W0950200020	16	16	8	16	M8	32	42	8	22	48
W0950322020	20	20	10	20	M10x1.25	40	52	10	26	92
W0950322020	25	20	10	20	M10x1.25	40	52	10	26	92
W0950322020	32	20	10	20	M10x1.25	40	52	10	26	92
W0950322020	40	20	10	20	M10x1.25	40	52	10	26	92
W0950402020	50	24	12	24	M12x1.25	48	62	12	32	148
W0950402020	63	24	12	24	M12x1.25	48	62	12	32	148
W0950502020	80	32	16	32	M16x1.5	64	83	16	40	340
W0950802020	100	40	20	40	M20x1.5	80	105	20	48	690

Note: Individually packed.



BALL-AND-SOCKET JOINT - MODEL GA-M

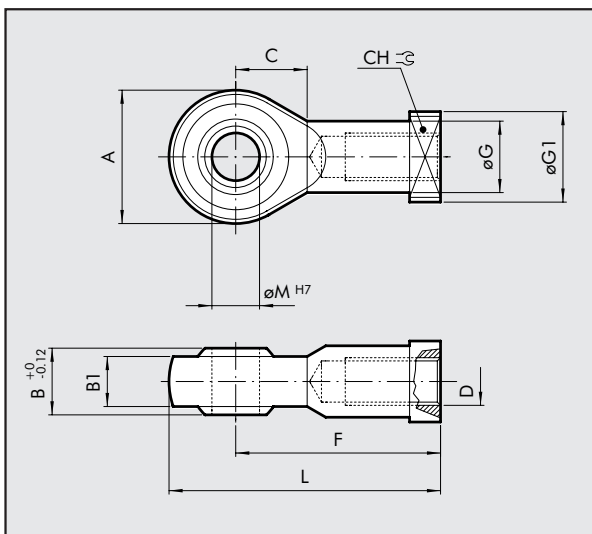

UNITOP-ISO codes	Ø	A	B	B1	C	CH	D	F	ØG	ØG1	L	ØM	Weight [g]
W0950120025	12	20	9	6.75	11	11	M6	30	10	13	40	6	28
W0950200025	16	24	12	9	13	14	M8	36	12.5	16	48	8	50
W0950322025	20	28	14	10.5	15	17	M10x1.25	43	15	19	57	10	78
W0950322025	25	28	14	10.5	15	17	M10x1.25	43	15	19	57	10	78
W0950322025	32	28	14	10.5	15	17	M10x1.25	43	15	19	57	10	78
W0950322025	40	28	14	10.5	15	17	M10x1.25	43	15	19	57	10	78
W0950402025	50	32	16	12	17	19	M12x1.25	50	17.5	22	66	12	116
W0950402025	63	32	16	12	17	19	M12x1.25	50	17.5	22	66	12	116
W0950502025	80	42	21	15	23	22	M16x1.5	64	22	27	85	16	226
W0950802025	100	50	25	18	27	30	M20x1.5	77	27.5	34	102	20	404

Note: Individually packed.

FLEXIBLE COLLAR - MODEL GA

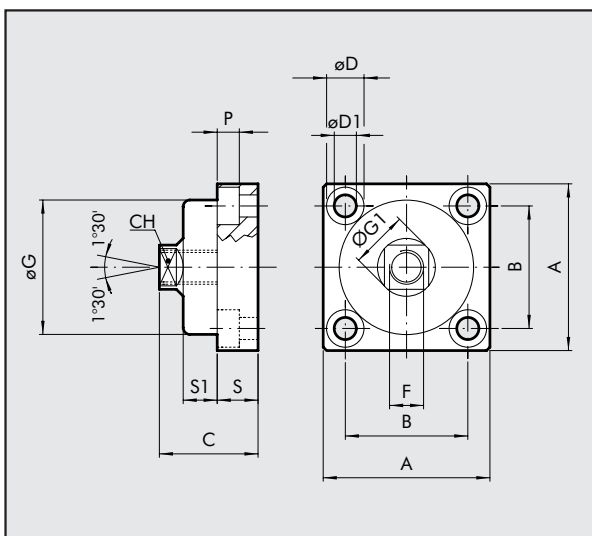

UNITOP-ISO Codes	Ø	A	B	C	CH	ØD	ØD1	F	ØG	ØG1	P	S	S1	Weight [g]
W0950326021	20	49	36	30	13	11	6.5	M10x1.25	39.5	17	6.5	12	10	172
W0950326021	25	49	36	30	13	11	6.5	M10x1.25	39.5	17	6.5	12	10	172
W0950326021	32	49	36	30	13	11	6.5	M10x1.25	39.5	17	6.5	12	10	172
W0950326021	40	49	36	30	13	11	6.5	M10x1.25	39.5	17	6.5	12	10	172
W0950406021	50	59	42	36	15	14	8.5	M12x1.25	44	19	8.5	15	13.5	286
W0950406021	63	59	42	36	15	14	8.5	M12x1.25	44	19	8.5	15	13.5	286
W0950506021	80	79	58	44	22	17	10.5	M16x1.5	59	26	10.5	20	15	628
W0950806021	100	89	65	51	27	19	12.5	M20x1.5	69	31	12.5	20	20	1200

Note: Individually packed.

CETOP COUNTER-HINGE Ø 32 ÷ 100

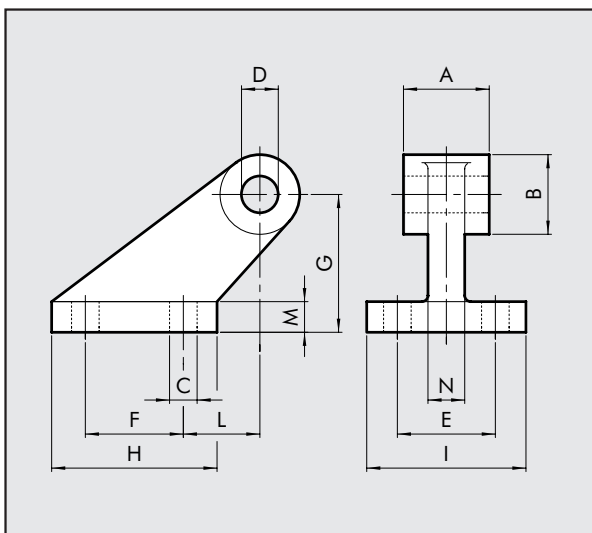

UNITOP-ISO Codes	Ø	A	B	C	D	E	F	G	H	I	L	M	N	Weight [g]
W0950322008	32	26	19	7	10	25	20	32	37	41	18	8	10	96
W0950402008	40	28	26	9	12	32	32	45	54	52	25	10	12	216
W0950502008	50	32	26	9	12	32	32	45	54	52	25	10	12	212
W0950632008	63	40	33	11	16	40	50	63	75	63	32	12	15	440
W0950802008	80	50	33	11	16	40	50	63	75	63	32	12	15	464
W0951002008	100	60	44	14	20	50	70	90	103	80	40	16	22	985

Note: Supplied complete with 4 screws, 4 washers.

COUNTER-HINGE Ø 16÷25 - MODEL BC

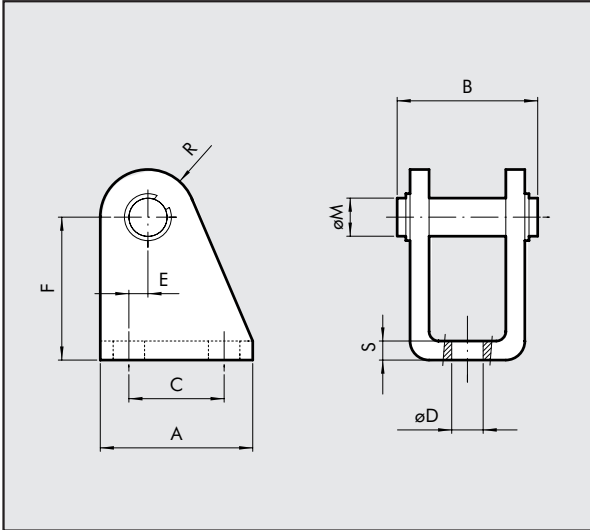

UNITOP Codes	Ø	A	B	C	ØD	E	F	ØM	R	S	Weight [g]
W0950120005	12	25	25	15	5.5	2	27	6	7	3	40
W0950120005	16	25	25	15	5.5	2	27	6	7	3	40
W0950200005	20	32	30	20	6.5	4	30	8	10	4	78
W0950200005	25	32	30	20	6.5	4	30	8	10	4	78

Note: Supplied complete with 1 pin and and 2 snap rings

ARTICULATED JOINT - MODEL GA-K

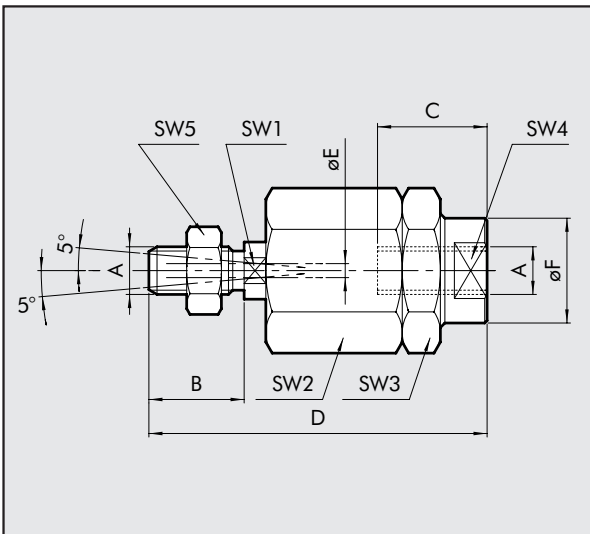

UNITOP-ISO Codes	Ø	A	B	C	D	ØE	ØF	SW1	SW2	SW3	SW4	SW5	Weight [g]
W0950120030	12	M6	10	10	35	2	8.5	5	13	13	7	10	24
W0950200030	16	M8	20	20	57	4	12.5	7	17	17	11	13	56
W0950322030	20	M10x1.25	20	20	71	4	22	12	30	30	19	17	216
W0950322030	25	M10x1.25	20	20	71	4	22	12	30	30	19	17	216
W0950322030	32	M10x1.25	20	20	71	4	22	12	30	30	19	17	216
W0950322030	40	M10x1.25	20	20	71	4	22	12	30	30	19	17	216
W0950402030	50	M12x1.25	24	20	75	4	22	12	30	30	19	19	220
W0950402030	63	M12x1.25	24	20	75	4	22	12	30	30	19	19	220
W0950502030	80	M16x1.5	32	32	103	4	32	20	41	41	30	24	620
W0950802030	100	M20x1.5	40	40	119	4	32	20	41	41	30	30	680

Note: Individually packed.

KIT FOR CYLINDER ASSEMBLY WITH SENSOR SLOTS

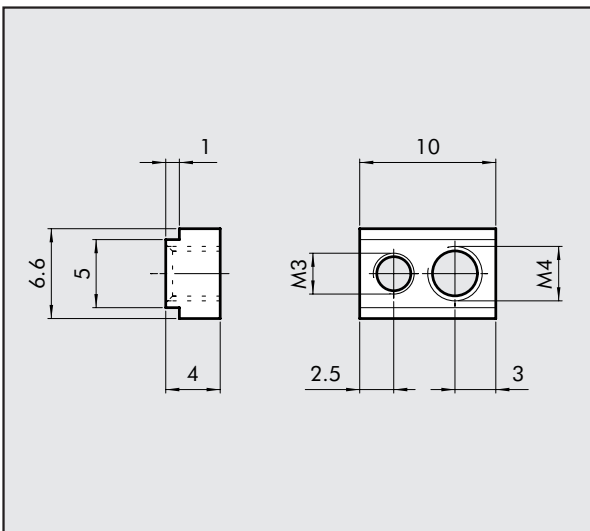

Code	Description	Weight [g]
0950003000	FIXING BLOCK	2

Note: Supplied complete with 1 M3 grub screw and 1 M4 grub screw.



RETRACTABLE SENSOR WITH INSERTION FROM ABOVE

1

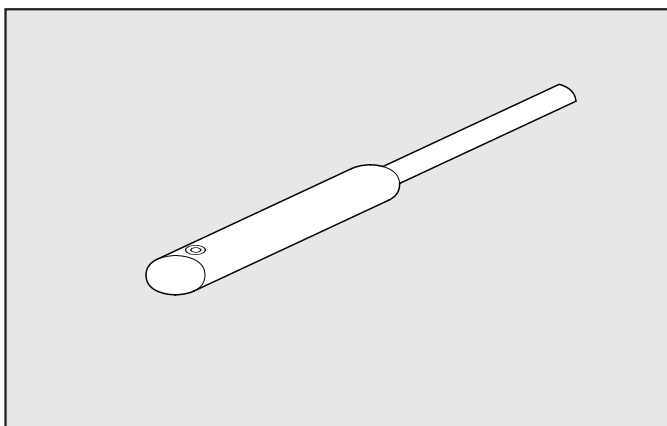

Code	Description
W0952025390	HALL N.O. SENSOR, VERTICAL INSERTION 2.5m
W0952029394	HALL N.O. SENSOR, VERTICAL INSERTION 300 mm M8
W0952022180	REED N.O. SENSOR, VERTICAL INSERTION 2.5m
W0952028184	REED N.O. SENSOR, VERTICAL INSERTION 300 mm M8

This type of sensor can be inserted in the slot of the sensor from above. This means the cylinder heads do not require a through opening.

WIRING DIAGRAM

TECHNICAL DATA

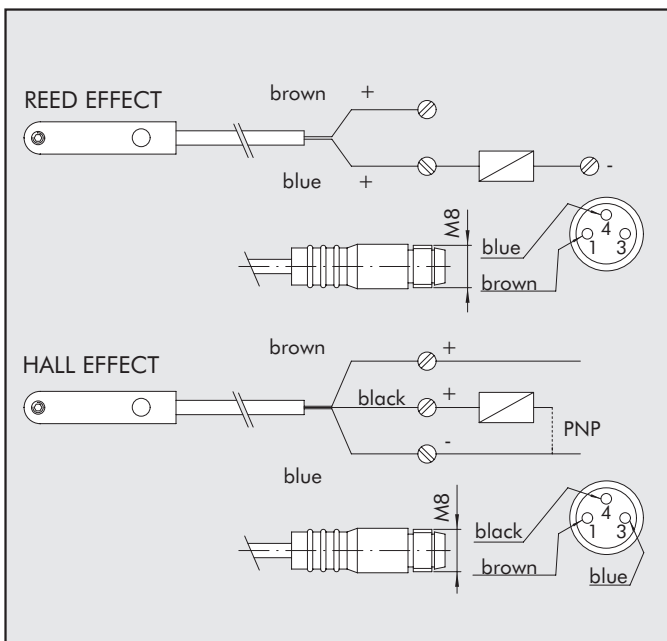

	Reed	Effetto Hall
Type of contact	N.O.	N.O.
Switch	-	PNP
Supply voltage (U _b)	V 10 ÷ 30 AC/DC	10 ÷ 30 DC
Power	W 3 (peak valve=6)	3
Voltage variation	-	≤ 10% di U _b
Voltage drop	V -	≤ 2
Input current	mA -	≤ 10
Output current	mA ≤ 100	≤ 100
Switching frequency	Hz ≤ 400	≤ 5
Short-circuit protection	-	Yes
Over-voltage suppression	-	Yes
Polarity inversion protection	-	Yes
EMC	EN 60 947-5-2	EN 60 947-5-2
LED display	Yellow	Yellow
Magnetic sensitivity	2,8 mT ±25%	2,8 mT ±25%
Repeatability	≤ 0,1 mT	≤ 0,1 mT
Degree of protection (EN 60529)	IP 67	IP 67
Vibration and shock resistance	30 g, 11 ms, 10÷55 Hz, 1mm	30 g, 11 ms, 10÷55 Hz, 1mm
Temperature range	°C -25 ÷ +75	-25 ÷ +75
Sensor capsule material	PA66 + PA6I/6T	PA66 + PA6I/6T
2.5m connecting cable	PVC; 2 x 0,12 mm ²	PVC; 3 x 0,14 mm ²
Connecting cable with M8x1	Polyurethane; 2 x 0,14 mm ²	Polyurethane; 3 x 0,14 mm ²

STRIP

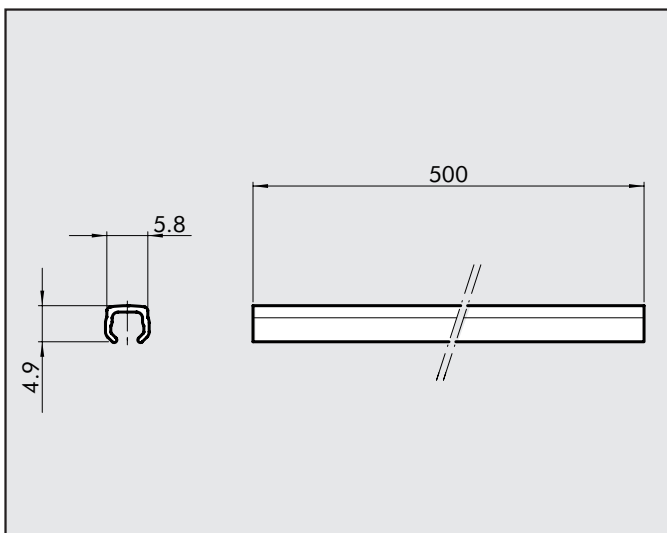

Code	Description
W0950000160	SLOT STRIP 500 mm

Note: The code corresponds to 1 piece.

SPARE PARTS

COMPACT CYLINDERS, SERIES CMPC

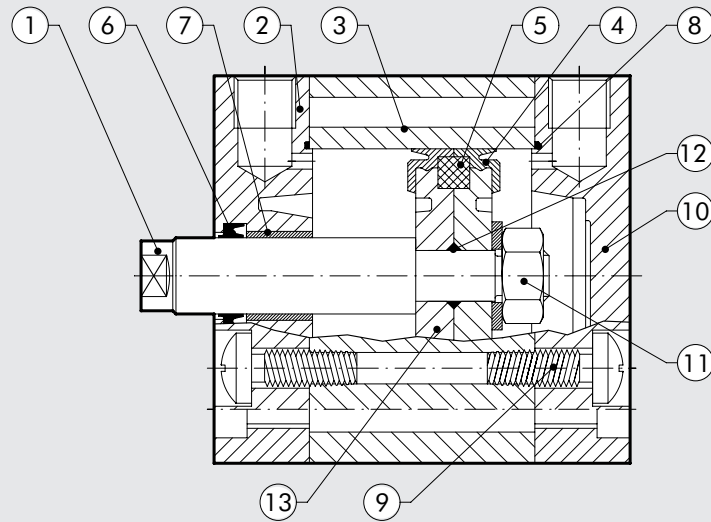

Type	Parts	Bores	Codes
Complete set of gaskets	④ ⑥ ⑧	∅ 12÷100	009 ... 7001
Front cylinder head kit for UNITOP	② ⑦ ⑥ ⑧	∅ 12÷100	009 ... 7101
Front cylinder head kit for ISO ∅ 32	② ⑦ ⑥ ⑧	∅ 32	0090327101
Front cylinder head kit for ISO	② ⑦ ⑥ ⑧	∅ 40÷100	009 ... 8101
Rear cylinder head kit for UNITOP	⑧ ⑩	∅ 12÷100	009 ... 7201
Rear cylinder head kit for ISO ∅ 32	⑧ ⑩	∅ 32	0090327201
Rear cylinder head kit for ISO	⑧ ⑩	∅ 40÷100	009 ... 8201
Front + rear cylinder head kit for UNITOP	② ⑦ ⑥ ⑧ ⑩	∅ 12÷100	009 ... 7301
Front + rear cylinder head kit for ISO ∅ 32	② ⑦ ⑥ ⑧ ⑩	∅ 32	0090327301
Front + rear cylinder head kit for ISO	② ⑦ ⑥ ⑧ ⑩	∅ 40÷100	009 ... 8301
Piston kit	④ ⑤ ⑪ ⑫ ⑬	∅ 12÷100	009 ... 7401
Magnet	⑤	∅ 12÷100	009 ... 7501
Front + rear cylinder head + piston kit for UNITOP	② ④ ⑤ ⑥ ⑦ ⑧ ⑩ ⑪ ⑫ ⑬	∅ 12÷100	009 ... 7901
Front + rear cylinder head + piston kit for ISO ∅ 32	② ④ ⑤ ⑥ ⑦ ⑧ ⑩ ⑪ ⑫ ⑬	∅ 32	0090327901
Front + rear cylinder head + piston kit for ISO	② ④ ⑤ ⑥ ⑦ ⑧ ⑩ ⑪ ⑫ ⑬	∅ 40÷100	009 ... 8901