

TWIN RODS CYLINDER

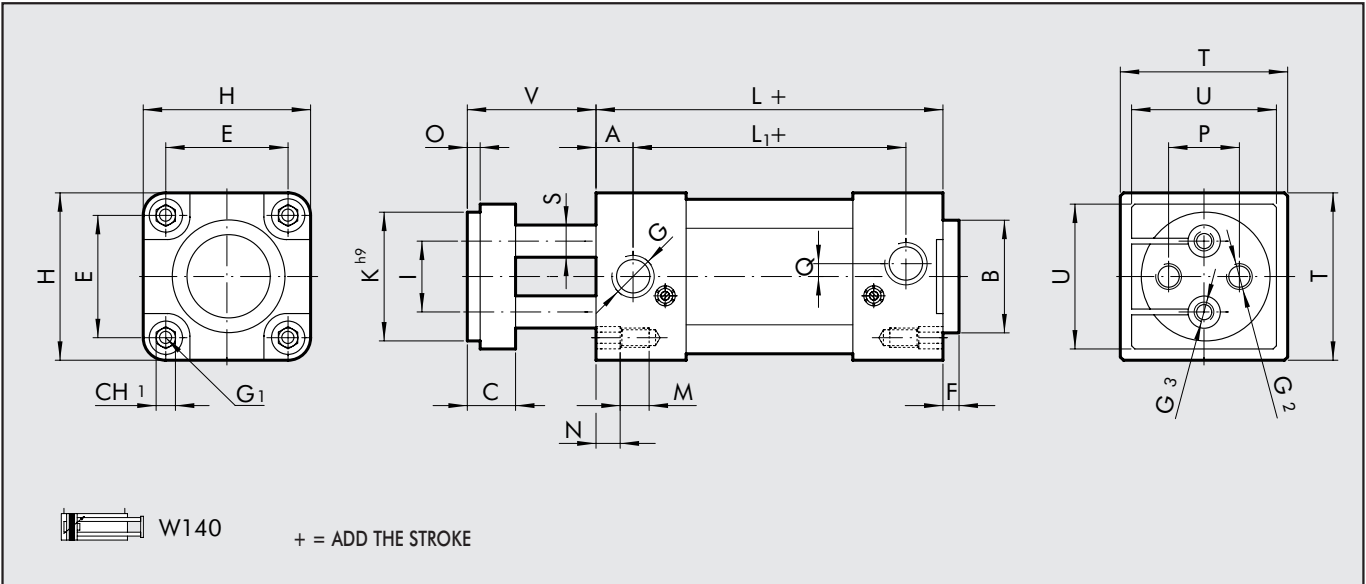

Ø	A	B	C	E	F	G	G ₁	G ₂	G ₃	H	K	I	L	L ₁	M	N	O	P	Q	S	T	U	V	CH1
32	13	30	15	32.5	5	G1/8	M6	M6	-	47	32	18	100	77	9	5.5	4	19	4	10	47	45	40	6
40	11.5	35	15	38	5	G1/4	M6	M8	-	53	40	22	100	76.5	9	5.5	4	22	4	10	52	50	40	6
50	14	40	18	46.5	5	G1/4	M8	M8	M8	65	50	30	106	78	12	5.5	5	30	6	12	65	55	43	8
63	14	45	22	56.5	5	G3/8	M8	M10	M10	75	63	38	116	86	12	5.5	5	38	6	16	75	70	47	8
80	15	45	25	72	8	G3/8	M10	M12	M12	95	80	48	131	98	16	5.5	5	50	7	22	95	90	50	10
100	15	55	25	89	8	G1/2	M10	M12	M12	115	100	60	138	103	16	5.5	5	70	7	22	115	110	50	10

SINGLE THROUGH-ROD CYLINDER

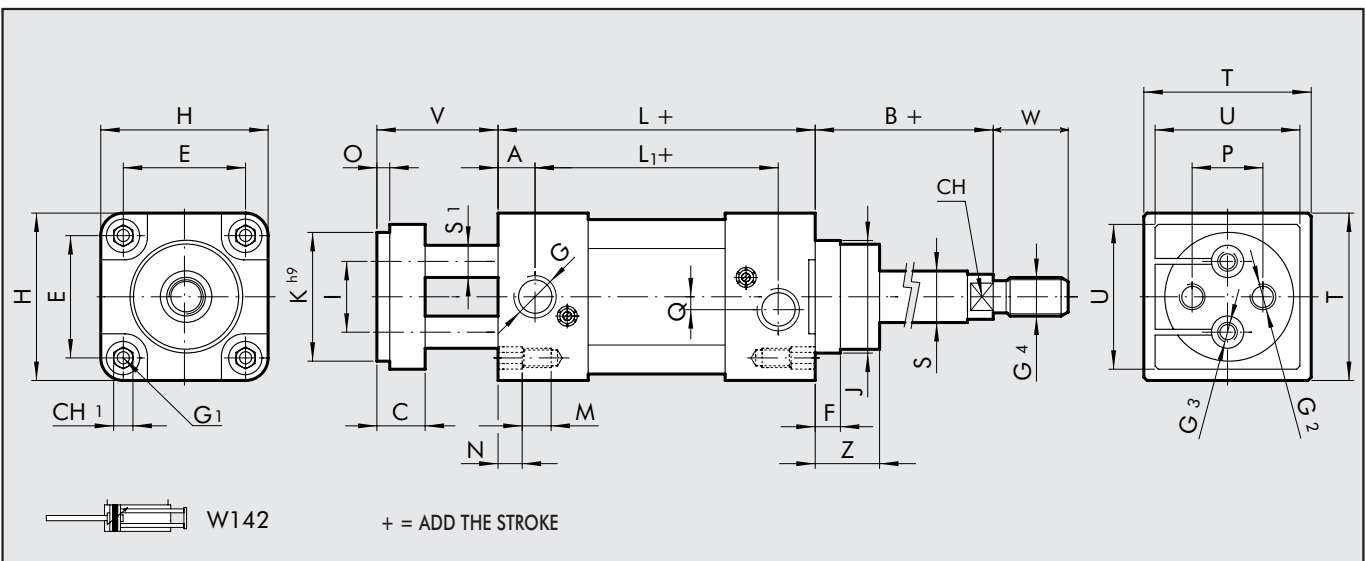

Ø	A	B	C	E	F	G	G ₁	G ₂	G ₃	G ₄	H	J	K	I	L	L ₁	M	N	O	P	Q	S	S ₁	T	U	V	W	Z	CH	CH1
32	13	26	15	32.5	7	G1/8	M6	M6	-	M10x1.25	47	30	32	18	100	77	9	5.5	4	19	4	12	10	47	45	40	22	16	10	6
40	11.5	30	15	38	9	G1/4	M6	M8	-	M12x1.25	53	35	40	22	100	76.5	9	5.5	4	22	4	16	10	52	50	40	24	20	13	6
50	14	37	18	46.5	14	G1/4	M8	M8	M8	M16x1.5	65	40	50	30	106	78	12	5.5	5	30	6	20	12	65	55	43	32	25	17	8
63	14	37	22	56.5	14	G3/8	M8	M10	M10	M16x1.5	75	45	63	38	116	86	12	5.5	5	38	6	20	16	75	70	47	32	25	17	8
80	15	46	25	72	12	G3/8	M10	M12	M12	M20x1.5	95	45	80	48	131	98	16	5.5	5	50	7	25	22	95	90	50	40	33	22	10
100	15	51	25	89	17	G1/2	M10	M12	M12	M20x1.5	115	55	100	60	138	103	16	5.5	5	70	7	25	22	115	110	50	40	38	22	10

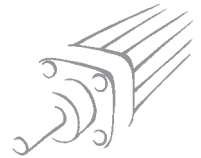

ACCESSORIES: FIXINGS

LEGS - MODEL A/S

Code	∅	AB	AH	AO	AT	AU	TR	UH	H ₁	H ₂	Weight [g]
W0950323001	32	7	32	35	4	24	32	45	164	148	76
W0950403001	40	9	36	43	4	28	36	52	168	156	98
W0950503001	50	9	45	47	4	32	45	65	181	170	156
W0950633001	63	9	50	47	6	32	50	75	195	180	246
W0950803001	80	12	63	61	6	41	63	95	222	213	406
W0951003001	100	14	71	66	6	41	75	115	229	220	540

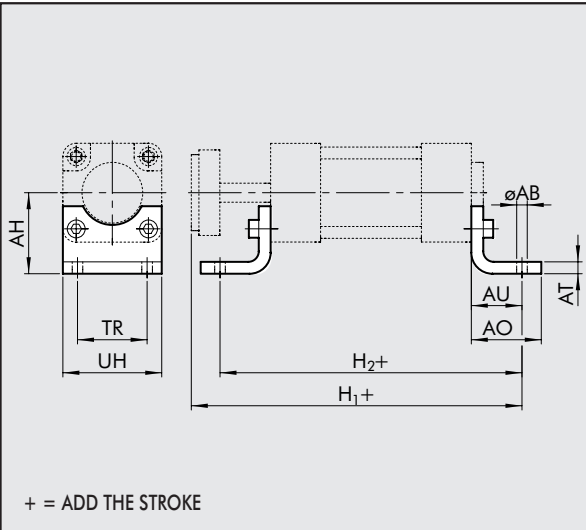

Note: Individually packed with 2 screws.

For fixing the leg to the supporting surface, it is advisable to use a DIN 7984 sunk-headed screw.

FEMALE HINGE - MODEL B

Code	∅	D	E	F	G	H	H ₃	L	Weight [g]
W0950322003	32	26	22	11	10	10	162	45	116
W0950402003	40	28	25	13	12	10	165	52	160
W0950502003	50	32	27	13	12	12	176	60	252
W0950632003	63	40	32	17	16	12	195	70	394
W0950802003	80	50	36	17	16	16	217	90	670
W0951002003	100	60	41	21	20	16	229	110	1085

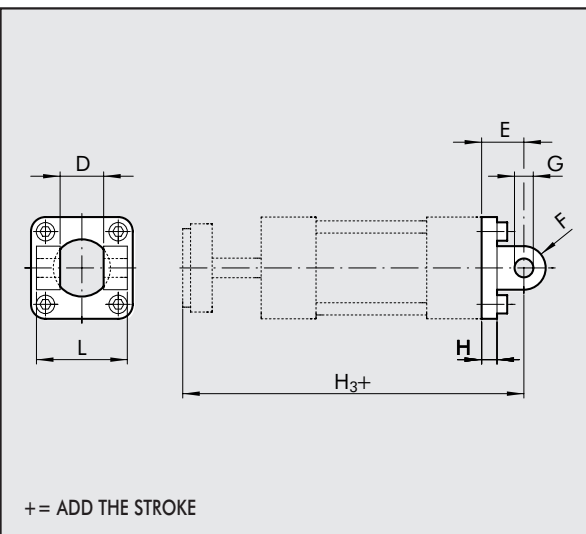

Note: Supplied with 4 screws, 4 washers, 2 snap-rings and 1 pin.

MALE HINGE - MODEL BA

Code	∅	D	E	F	G	H	H ₃	Weight [g]
W0950322004	32	26	22	11	10	10	162	94
W0950402004	40	28	25	13	12	10	165	124
W0950502004	50	32	27	13	12	12	176	220
W0950632004	63	40	32	17	16	12	195	316
W0950802004	80	50	36	17	16	16	217	578
W0951002004	100	60	41	21	20	16	229	850

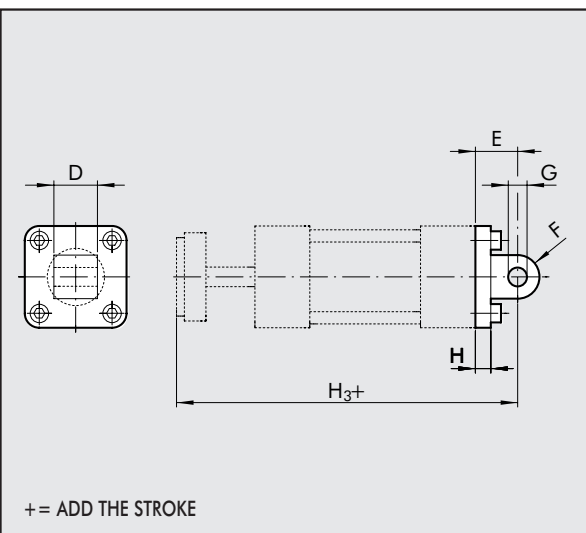

Note: Supplied with 4 screws, 4 washers.

ARTICULATED MALE HINGE - MODEL BAS

Code Ø E F H H₃ M N Weight [g]

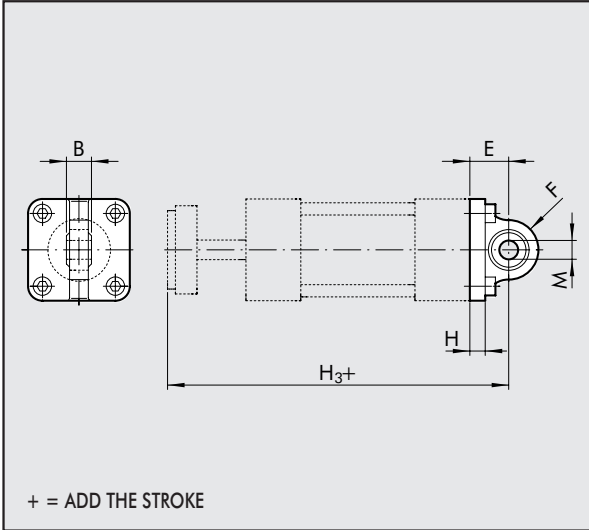

W0950322006	32	22	16	10	162	10	14	106
W0950402006	40	25	19	10	165	12	16	142
W0950502006	50	27	19	12	176	12	16	236
W0950632006	63	32	24	12	195	16	21	336
W0950802006	80	36	24	16	217	16	21	572
W0951002006	100	41	30	16	229	20	25	840

Note: Supplied with 4 screws, 4 washers.

REAR FLANGE - MODEL C

Code Ø B B₁ B₂ B₃ B₄ D₄ L Weight [g]

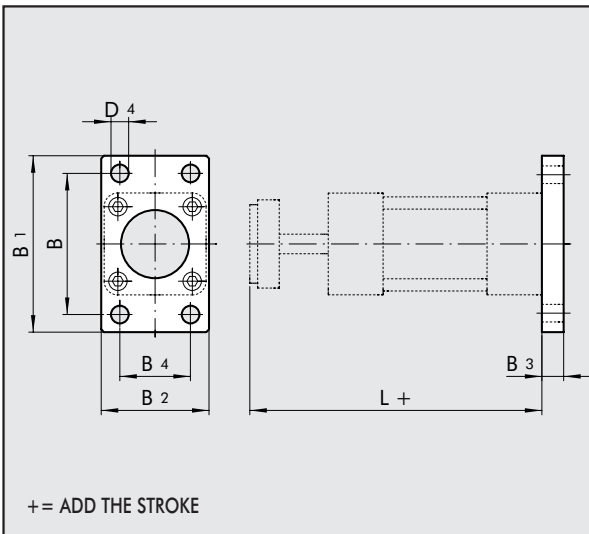

W0950322002	32	64	80	50	10	32	7	140	246
W0950402002	40	72	90	55	10	36	9	140	290
W0950502002	50	90	110	65	12	45	9	149	522
W0950632002	63	100	120	75	12	50	9	163	670
W0950802002	80	126	153	95	16	63	12	181	1420
W0951002002	100	150	178	115	16	75	14	188	2040

Note: Supplied with 4 screws.

FRONT FLANGE - MODEL C

Code Ø B B₁ B₂ B₃ B₄ D₄ V₁ Weight [g]

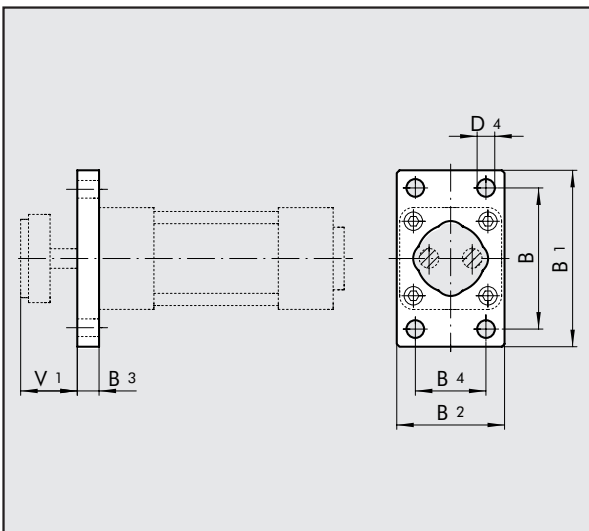

W0950323002	32	64	80	50	10	32	7	30	228
W0950403002	40	72	90	55	10	36	9	30	288
W0950503002	50	90	110	65	12	45	9	31	486
W0950633002	63	100	120	75	12	50	9	35	569
W0950803002	80	126	153	95	16	63	12	34	1145
W0951003002	100	150	178	115	16	75	14	34	1760

Note: Supplied with 4 screws.



INTERMEDIATE HINGE - MODEL EN

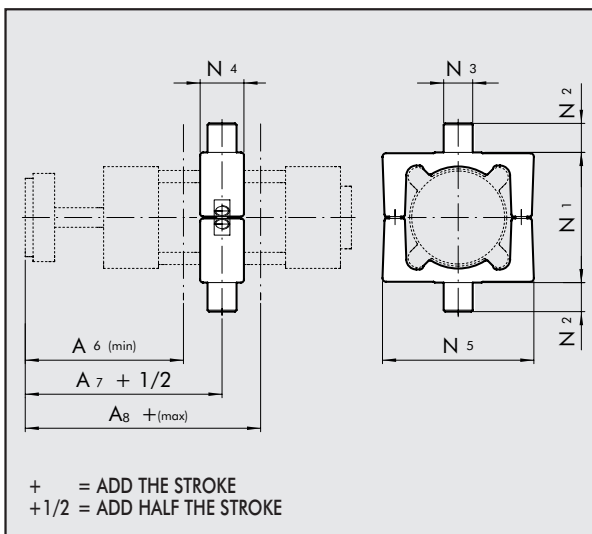

Code	Ø	N ₁	N ₂	N ₃	N ₄	N ₅	A ₆	A ₇	A ₈	Weight [g]
0950322007	32	50	12	12	22	65	79	91	103	282
0950402007	40	63	16	16	28	75	82	90	98	582
0950502007	50	75	16	16	32	95	91.5	97.5	103.5	880
0950632007	63	90	20	20	35	105	95.5	104.5	113.5	1230
0950802007	80	110	20	20	40	130	108	115.5	123	2030
0951002007	100	132	25	25	45	145	110.5	119	127.5	2600

Note: Supplied with 4 screws, 2 pin.

COUNTER-HINGE FOR MODEL EN - MODEL EL

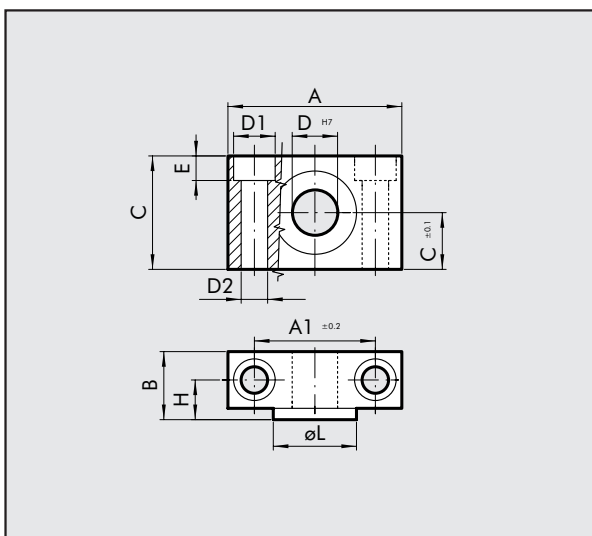

Code	Ø	A	A ₁	B	C	C ₁	D ₁	D ₂	D	E	H	ØL	Weight [g]
W0950322009	32	46	32	18	30	15	11	7	12	6.5	10.5	22	162
W0950402009	40	55	36	21	36	18	15	9	16	8.5	12	28	278
W0950402009	50	55	36	21	36	18	15	9	16	8.5	12	28	278
W0950632009	63	65	42	23	40	20	18	11	20	10.5	13	35	414
W0950632009	80	65	42	23	40	20	18	11	20	10.5	13	35	414
W0951002009	100	75	50	28.5	50	25	20	13	25	12.5	16	40	715

Note: Supplied with 4 screws.

CETOP COUNTER-HINGE FOR MODEL B MODEL GL

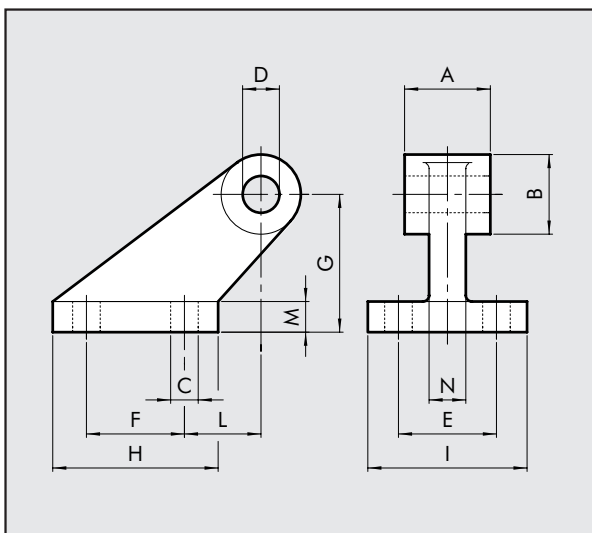

Code	Ø	A	B	C	D	E	F	G	H	I	L	M	N	Weight [g]
W0950322008	32	26	19	7	10	25	20	32	37	41	18	8	10	96
W0950402008	40	28	26	9	12	32	32	45	54	52	25	10	12	216
W0950502008	50	32	26	9	12	32	32	45	54	52	25	10	12	212
W0950632008	63	40	33	11	16	40	50	63	75	63	32	12	15	440
W0950802008	80	50	33	11	16	40	50	63	75	63	32	12	15	464
W0951002008	100	60	44	14	20	50	70	90	103	80	40	16	22	985

Note: Supplied with 4 screws, 4 washers.

**ISO COUNTER-HINGE FOR MODEL B
MODEL GS**

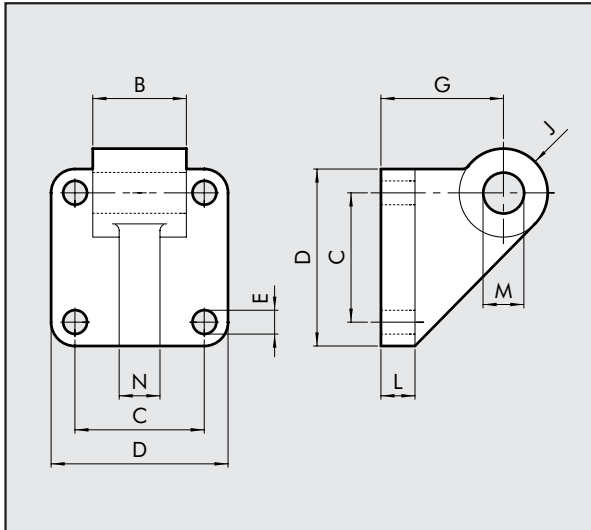

Code	Ø	B	C	D	E	G	J	L	M	N	Weight [g]
W0950322108	32	25.5	32.5	45	7	32	11	10	10	10	106
W0950402108	40	27.5	38	52	7	36	13	10	12	12	138
W0950502108	50	31.5	46.5	65	9	45	13	12	12	12	252
W0950632108	63	39.5	56.5	75	9	50	17	16	16	15	350
W0950802108	80	49.5	72	95	11	63	17	16	16	15	655
W0951002108	100	59.5	89	115	11	73	21	20	20	22	980

Note: Supplied with 4 screws, 4 washers.

ACCESSORIES: MAGNETIC SENSORS

ORDERING CODES

Code	Description
MAGNETIC PROXIMITY SENSORS	
W0950000201	REED SENSOR ACC. DSM2-C525
W0950000222	E.HALL PNP SENSOR ACC. DSM3-N225
W0950000232	E.HALL NPN SENSOR ACC. DSM3-M225

SENSOR BRACKET

W0950000711	BRACKET ACC. D.32-40 DST 80
W0950000712	BRACKET ACC. D.50-63 DST 81
W0950000713	BRACKET ACC. D.80-125 DST 82

NB: For technical features of sensors, see Accessories for ISO cylinders Ø 160-200, page 1.1/85.

SENSOR

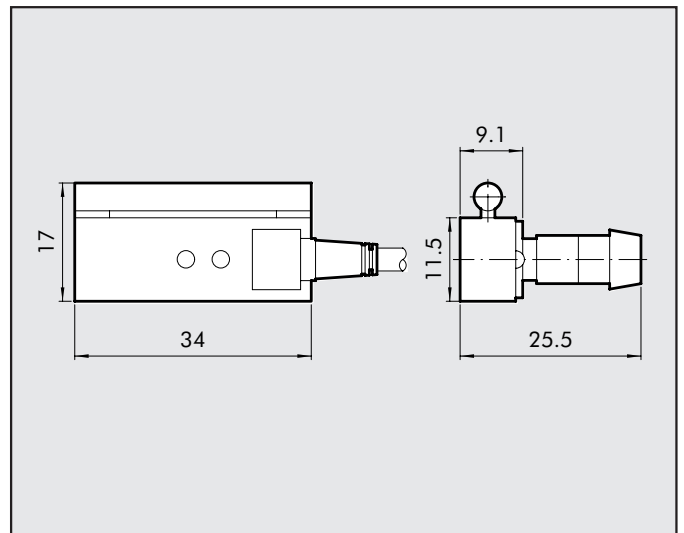

BRACKET Ø 32-40

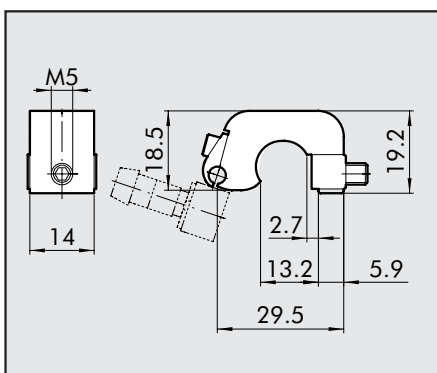

BRACKET Ø 50-63

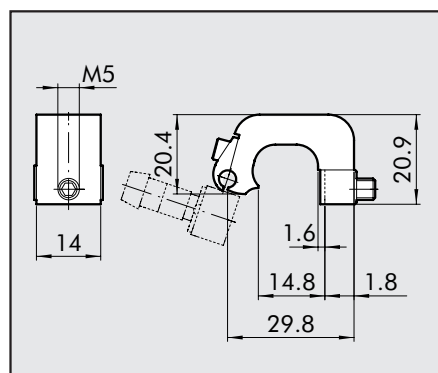

BRACKET Ø 80-100

