

RODLESS CYLINDER

Ø 16, 25, 32, 40, 63

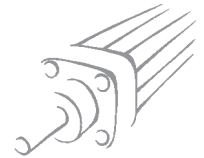

1

Rodless cylinders come in five different bores - Ø 16, 25, 32, 40 and 63 mm – and the design incorporates numerous innovations.

- Calibrated extruded anodized aluminium alloy jacket.
 - Sensor slots and accessory slots in the jacket itself.
 - Longitudinal seal by means of specially-shaped indeformable stainless steel strips.
 - Strokes 100 to 5700 mm with 1mm intervals.
 - Adjustable integrated pneumatic cushioning
 - Adjustable limit switches and decelerations can be applied at any time.
 - For this type of cylinder (size 32 and upwards), the valves can be fitted directly using the retracting sensors without requiring any intermediate brackets.
- Refer to the table on page 1.1/96.

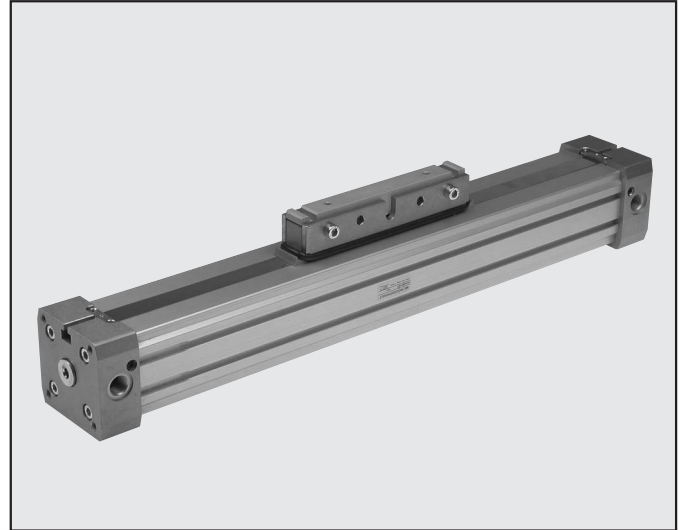

TECHNICAL DATA		NBR	FKM/FPM
Operating pressure	bar	1 ÷ 8	
	MPa	0.1 ÷ 0.8	
Temperature range	psi	14.5 ÷ 116	
	°C	-15 ÷ 80	
	°F	- 5 ÷ 176	
Fluid		50µm unlubricated filtered air Lubrication, if used, must be continuous.	
Bores	mm	Ø 16, 25, 32, 40 and 63	
Type of construction		Double-acting rodless cylinder with direct transmission system	
Strokes		for Ø 16 : 100 to 5000 mm with 1mm interval	
		for Ø 25, 32 and 40 : 100 to 5700 mm with 1mm interval	
		for Ø 63 : 100 to 5500 mm with 1mm interval	
Recommended speeds		V < 1 m/s (NBR)	V > 1 m/s (FKM/FPM)
Max. speed with decelerators		< 1 m/s (NBR)	2 m/s (FKM/FPM)
Weight		See GENERAL TECHNICAL DATA PAGE 1.1/07	
For versions no-stick slip, use no-lubricated air only			

COMPONENTS

- ① CYLINDER HEAD: aluminium alloy
- ② BARREL: profiled anodized aluminium alloy
- ③ PISTON GASKET: NBR or FKM/FPM
- ④ CENTRAL ELEMENT: aluminium alloy
- ⑤ SCRAPER: Hostaform®
- ⑥ O-RING: FKM/FPM
- ⑦ PISTON: Hostaform®
- ⑧ CUSHIONING CONE: aluminium alloy
- ⑨ STATIC O-RINGS: NBR or FKM/FPM
- ⑩ SLIDE: aluminium alloy
- ⑪ OUTER STRIP: stainless steel
- ⑫ INNER STRIP: stainless steel
- ⑬ BAND SUPPORT: Hostaform®

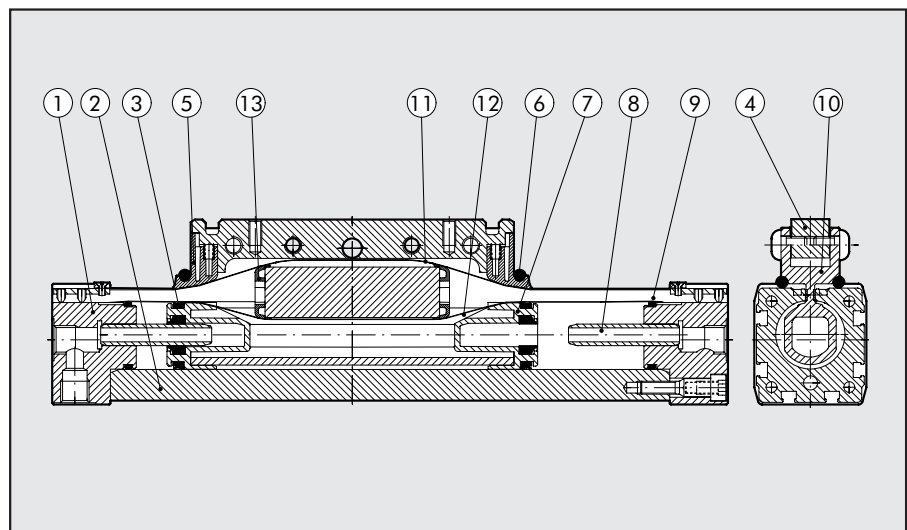

DIMENSIONING - FORCE AND TORQUE

Bore Ø	Centre Distance Y	Actual Force F at 6 bar [N]	Cushioning stroke [mm]	Max. load L [N]	Ma max [Nm]	Mr max [Nm]	Mv max [Nm]
16	9	110	15	120	4	0.3	0.5
25	14	250	21	300	15	1	3
32	18	420	26	450	30	2	4
40	22	640	32	750	60	4	8
63	44	1550	40	1650	200	8	24

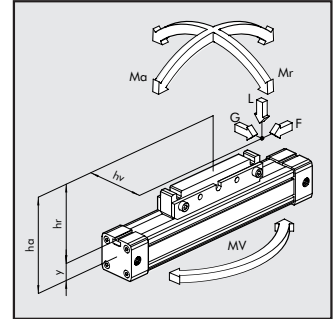

NB: When the cylinder is subjected simultaneously to torque and force, it is advisable to keep to the following equations.

$$Ma = F \times ha \quad Mr = L \times hv + G \times hr \quad Mv = F \times hv$$

$$\frac{Mv}{Mv_{max}} \leq 1; \quad \frac{L}{L_{max}} \leq 1; \quad \frac{Ma}{Ma_{max}} + \frac{Mr}{Mr_{max}} + 0.22 \times \frac{Mv}{Mv_{max}} + 0.4 \frac{L}{L_{max}} \leq 1$$

DIAGRAM OF SPEED AND MAXIMUM CUSHIONABLE LOAD

For the cylinder to reach the end-of-stroke position without intense or repeated impact which would damage it, it is necessary to annul the kinetic energy of the moving mass and the work generated. The maximum cushionable load depends on the traversing speed and the absorption of the air buffer supplied standard with the various cylinders. The diagram shows the speeds and cushionable mass for the various diameters at a pressure of 6 bar.

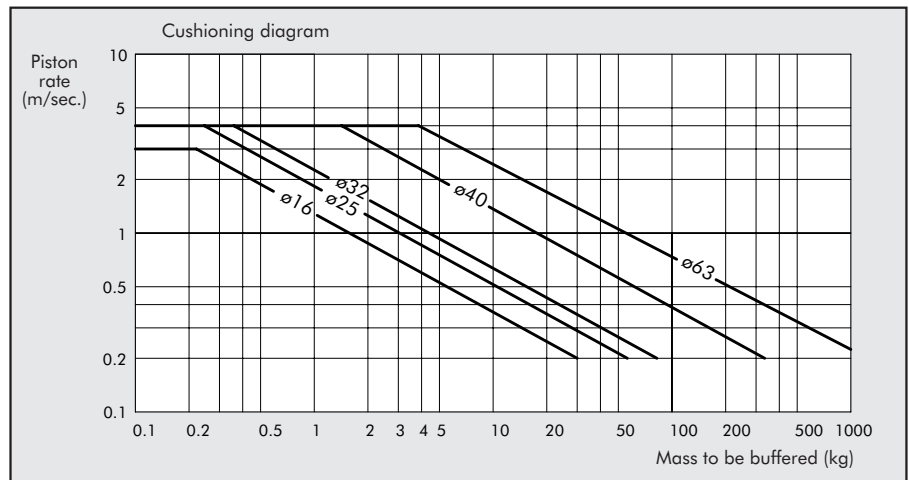

MAXIMUM LOAD ACCORDING TO THE DISTANCE BETWEEN SUPPORTS

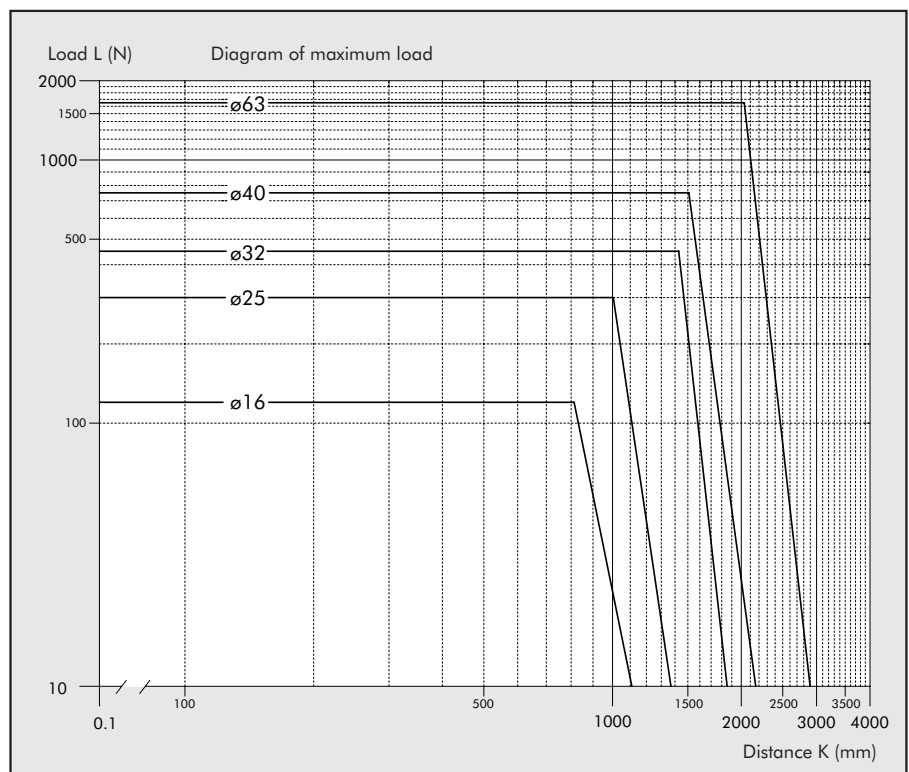
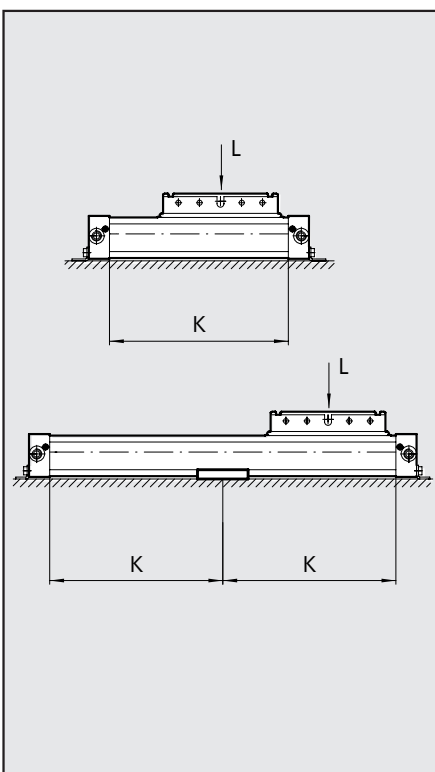

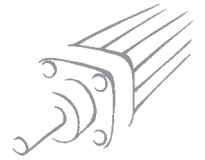

BARREL CROSS SECTION

1

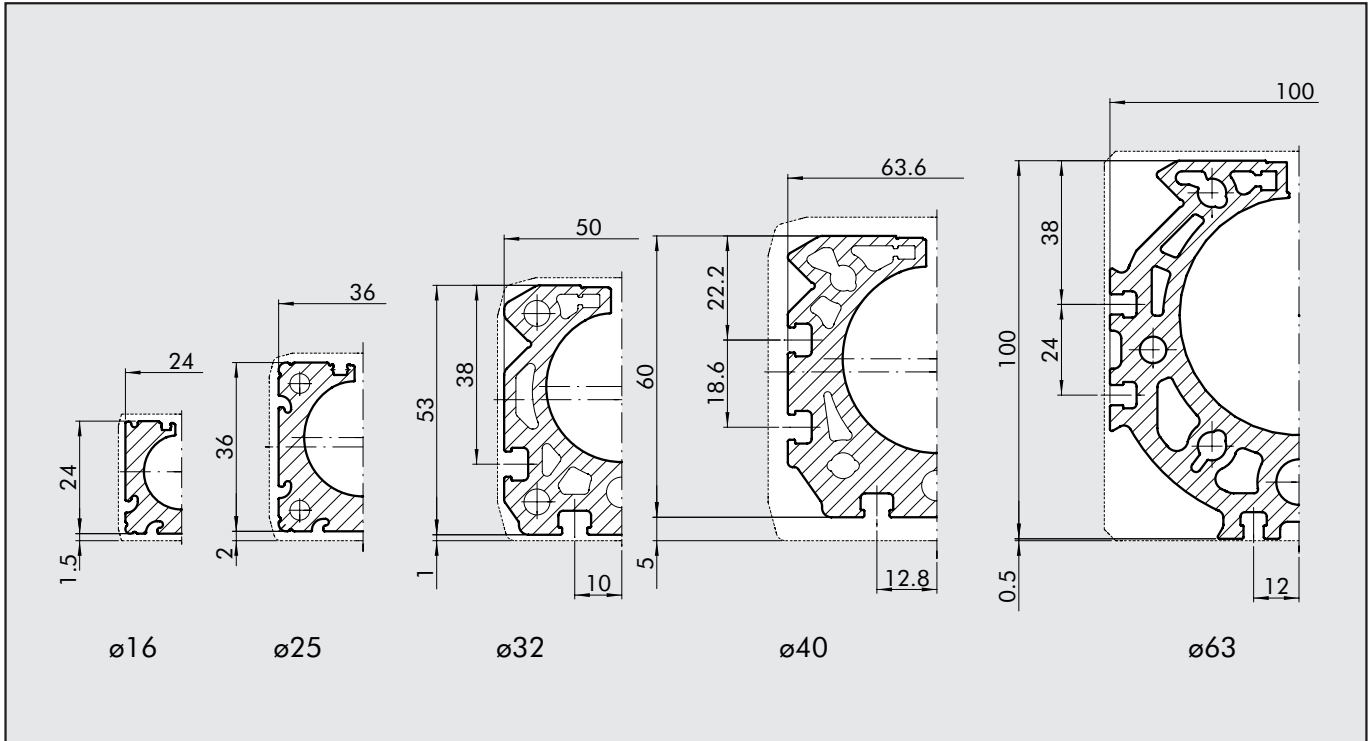

DIMENSIONS OF RODLESS CYLINDER $\varnothing 16 \div 40$

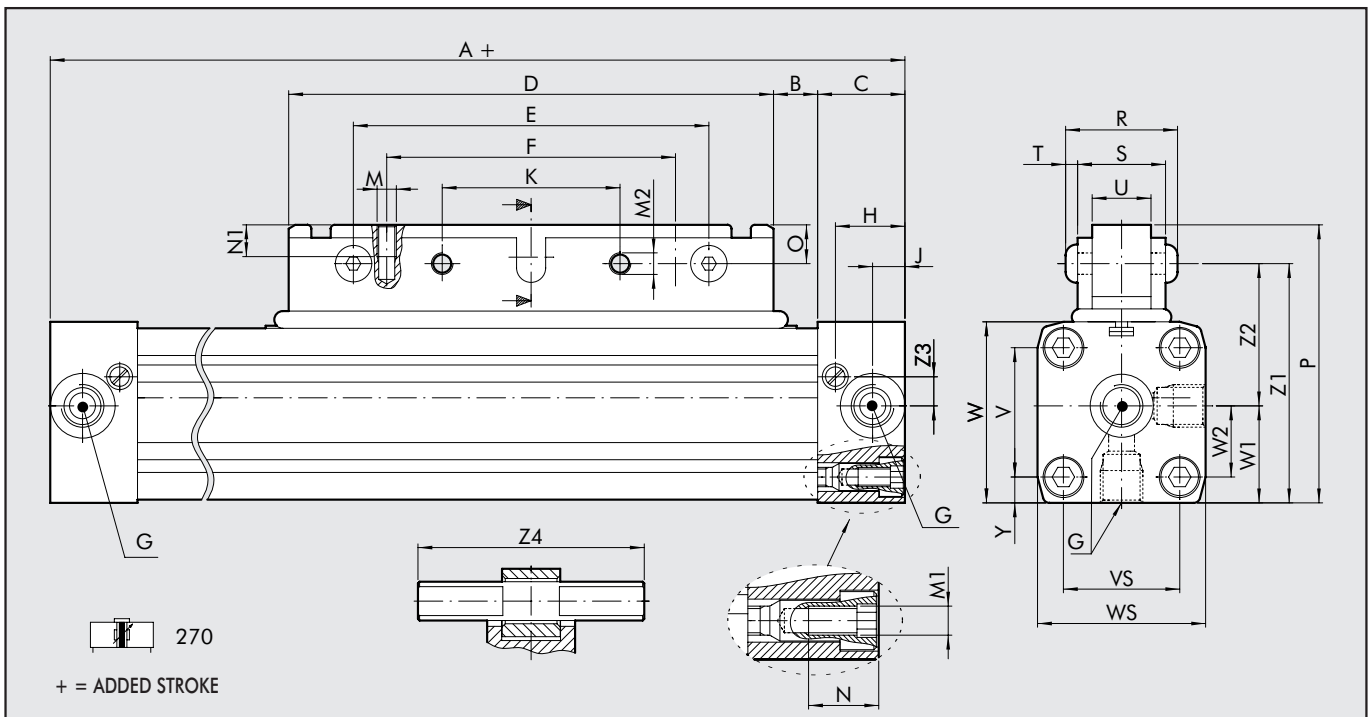

\varnothing	A	B	C	D	E	F	G	H	J	K	M	M1	M2	N	N1	O	P	R	S	T	U	V	VS	W	WS	W1	W2	Y	Z1	Z2	Z3	Z4
16	130	12	15	76	64	48	M5	12	6.4	32	M4	M3	M5	7	8	6	43.5	23.5	18	2.75	10	18	18	27	27	13.5	9	4.5	37.5	24	4.5	28
25	200	17	23	120	100	80	1/8	18.5	8.5	50	M5	M5	M6	12	11	13	66	29.6	23	3.3	15	27	27	40	40	20	13.5	6.5	53	33	6.5	42
32	250	23	27	150	110	90	1/4	22	10.5	55	M6	M6	M8	14	12	12	86	36	27	4.4	18	40	36	56	52	30	22	8	74	44	8	70
40	300	45	30	150	110	90	1/4	24	15	55	M6	M6	M8	17.5	12	12	97	36.8	28	4.4	18	54	54	69	72	36	27	9	85	49	11.8	70

DIMENSIONS OF RODLESS CYLINDER Ø 63

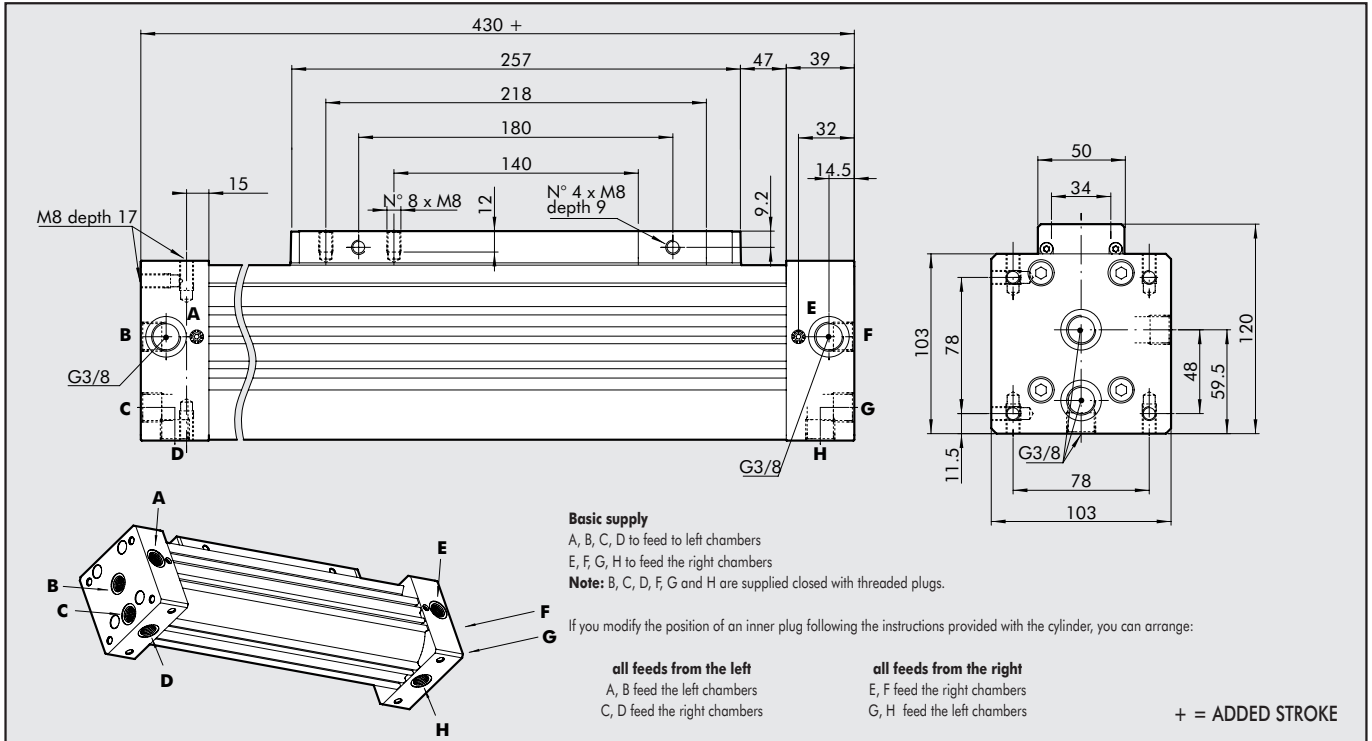

RODLESS CYLINDER WITH SWING CARRIAGE

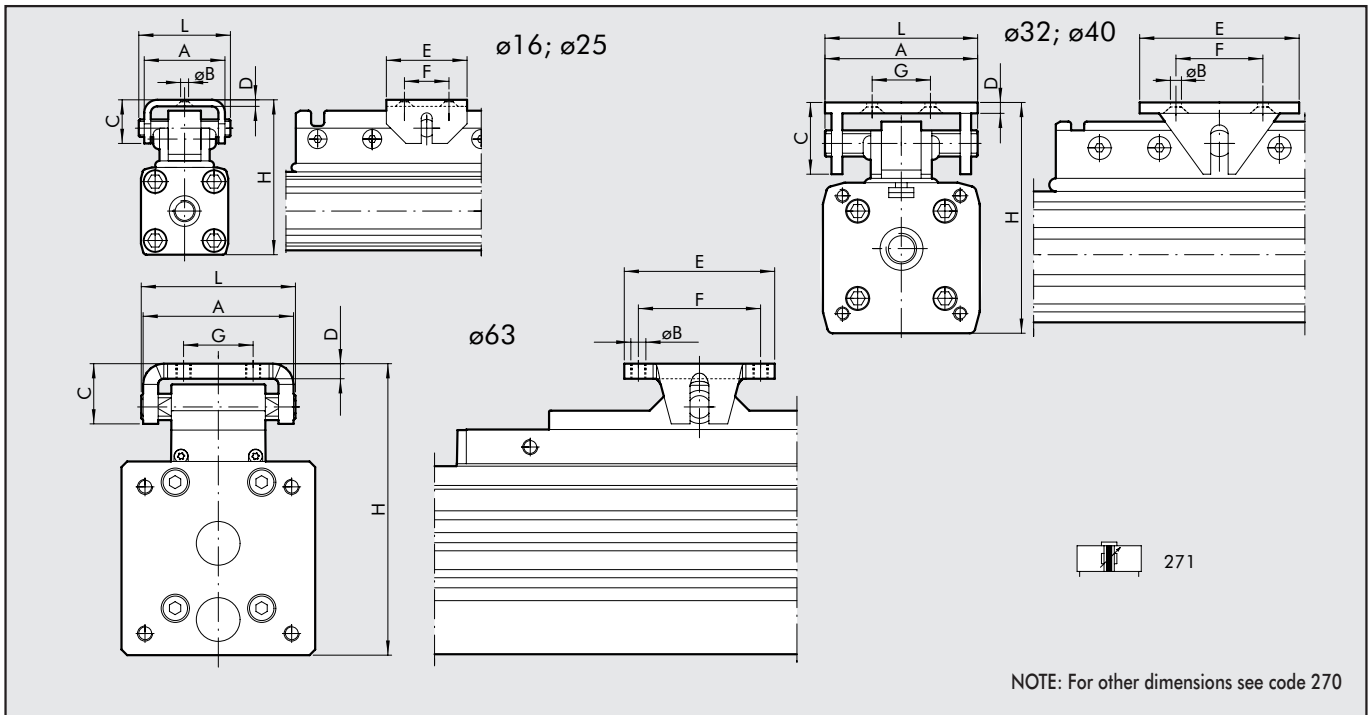

Ø	A	ØB	C	D	E	F	G	H	L
16	25	4.5	13	2	20	10	-	47-50	28
25	37	5.5	20	3	30	16	-	72-75	42
32	70	6.5	38	5	90	75	55	91-100	70
40	70	6.5	38	5	90	75	55	111-120	70
63	80	M8	32	8	80	65	37	155-162	82



DIMENSIONS OF RODLESS CYLINDER + ADJUSTABLE LIMIT SWITCH AND SHOCK ABSORBERS

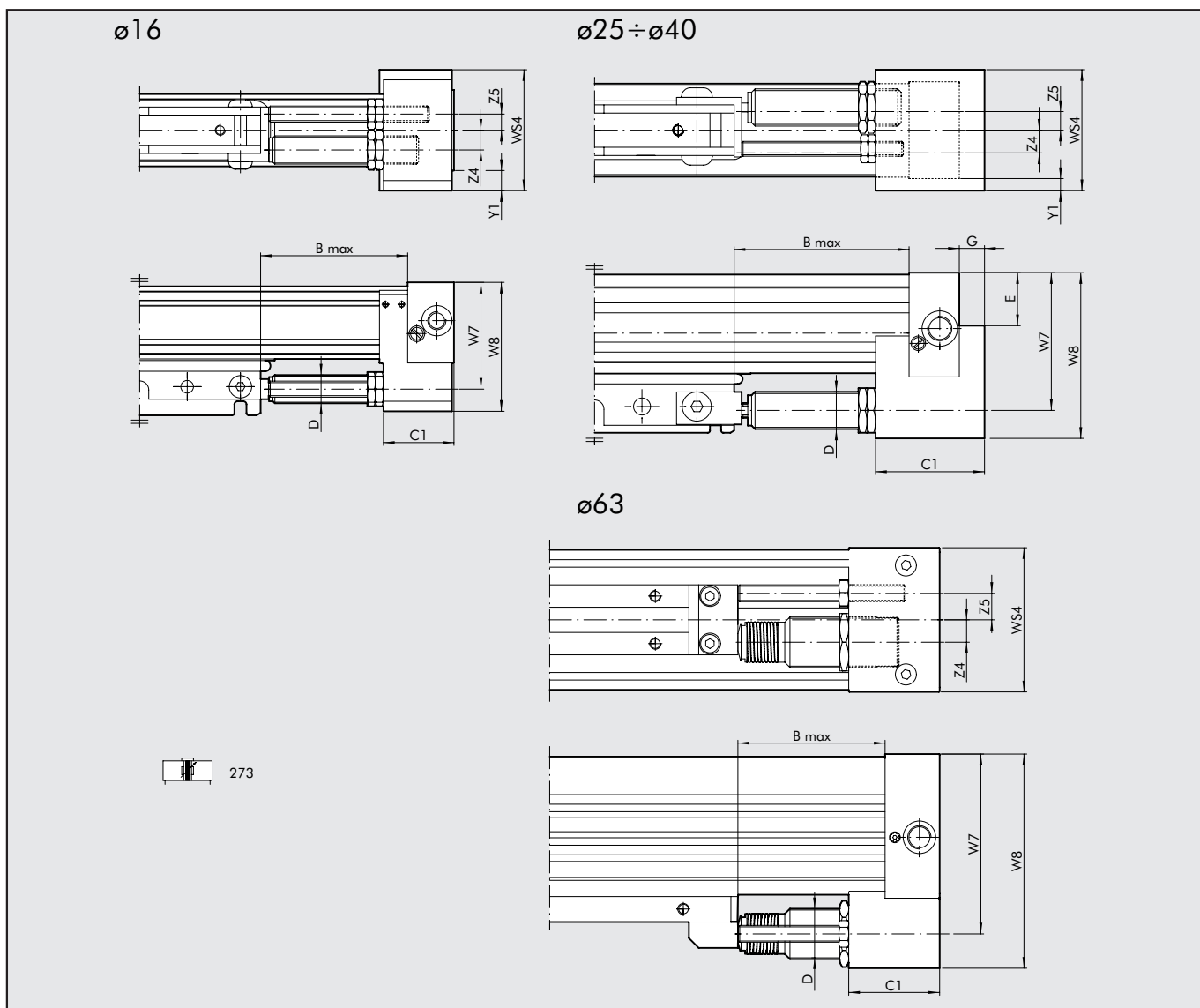

Ø	B Max	C1	D	E	G	W7	W8	WS4	Y1	Z4	Z5	Stroke	Max. cushioned force		Max. impact force [N]	Max. thrust force [N]
													for stroke [J]	for hour [J]		
16	42	22	M12x1	-	-	38	46	42	7.5	7	7.5	10	4.5	14125	1000	220
25	72	44	M14x1.5	17	9	53	67	50	5	8	9.8	16	18	34000	2800	530
32	90	56	M20x1.5	29	11	74	89	60	4	10	12.2	22	40	53700	3750	890
40	105	74	M25x1.5	32.8	14	89	108	75	1.5	12.5	12.7	25	65	70000	5500	1550
63	105	65	M36x1.5	-	-	128.5	153	103	-	16	19	25	125	91000	11120	2220

For graphs to help choose shock absorbers see page 1.1/124

KEY TO CODES

CYL	2	7	0	0	2 5	0	0	5	0	C	N
TYPE				BORE		STROKE			CONFIGURATION		
27	Rodless cylinder	0 1 +2 3	Standard With swing drive Twin cushioned series "Double" Double-acting cushioned Magnetic + adjustable limit switches and shock absorbers	0 magnetic S non-magnetic +G No stick slip	16 25 32 40 63	Ø 16: from 100 to 5000mm Ø 25÷40: from 100 to 5700 mm Ø63 from 100 to 5500 mm	C	N ●V FKM/FPM			

■ For speed ≤ 0.2 m/s ● For speed ≥ 1m/s + Available up to Ø 32

ACCESSORIES

FOOT Ø 16; 25

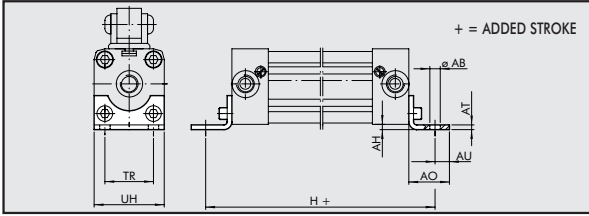

Code	Ø	ØAB	AH	AO	AT	AU	TR	UH	H	Weight [g]
------	---	-----	----	----	----	----	----	----	---	------------

W0950167001	16	3.6	1.5	14	1.6	4	18	26	150	10
W0950257001	25	5.5	2	22	2.5	6	27	40	232	32

Note: Individually packed with 2 screws.

FOOT Ø 32; 40

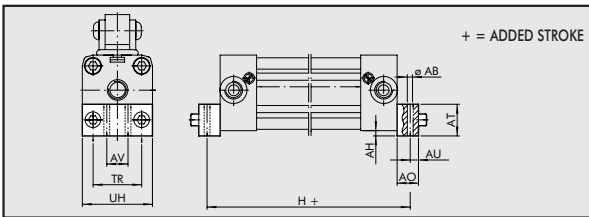

Code	Ø	ØAB	AH	AO	AT	AU	AV	TR	UH	H	Weight [g]
------	---	-----	----	----	----	----	----	----	----	---	------------

W0950327001	32	6.6	4	25	20	8	20	36	51	284	88
W0950407001	40	9	2	25	20	11.5	30	54	71	327	112

Note: Individually packed with 2 screws.

FOOT Ø 63

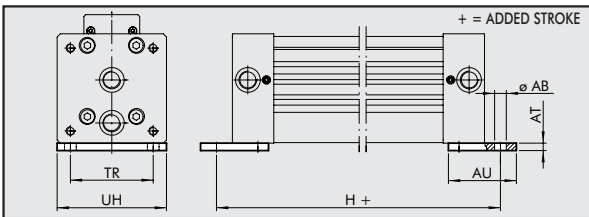

Code	Ø	ØAB	AT	AU	TR	UH	H	Weight [g]
------	---	-----	----	----	----	----	---	------------

W0950637001	63	11	7	64	78	103	460	360
-------------	----	----	---	----	----	-----	-----	-----

Note: Individually packed with 2 screws.

INTERMEDIATE FOOT Ø 16; 25

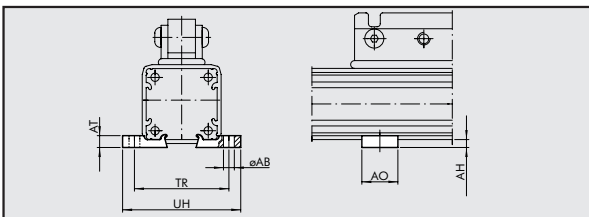

Code	Ø	ØAB	AH	AO	AT	TR	UH	Weight [g]
------	---	-----	----	----	----	----	----	------------

W0950167031	16	5.5	3	20	5	41	53	4
W0950257031	25	5.5	4	20	6	48	60	6

Note: Individually packed.

INTERMEDIATE FOOT Ø 32; 40

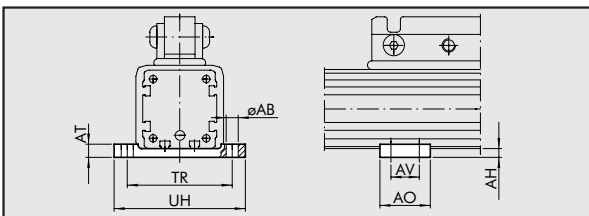

Code	Ø	ØAB	AH	AO	AT	AV	TR	UH	Weight [g]
------	---	-----	----	----	----	----	----	----	------------

W0950327032	32	6.5	5	55	8	40	61.5	73	72
W0950407032	40	6.5	7	60	8	45	70÷75	85	104

Note: plate supplied complete with 4 screws, 4 fixing plates

INTERMEDIATE FOOT Ø 63

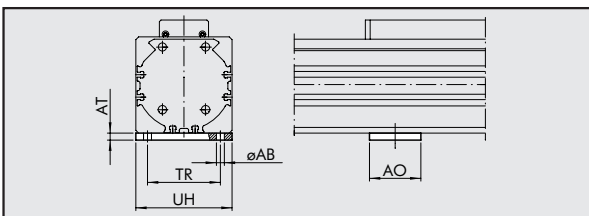

Code	Ø	ØAB	AH	AO	AT	TR	UH	Weight [g]
------	---	-----	----	----	----	----	----	------------

W0950637032	63	8.5	7.5	55	7.5	78	103	330
-------------	----	-----	-----	----	-----	----	-----	-----

Note: plate supplied complete with 4 screws, 4 fixing plates



KIT TO TRANSFORM INTO SWING VERSION

Code Ø Weight [g]

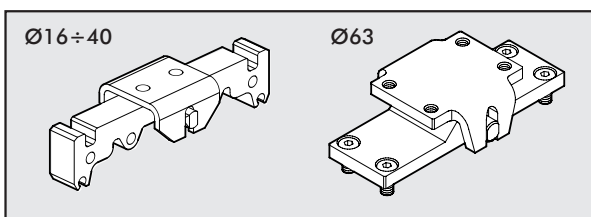

W0950167035	16	34
W0950257035	25	118
W0950327035	32	450
W0950327035	40	450
W0950637035	63	810

Note: ø16÷40: Supplied complete with 1 adaptor, 1 support, 1 pin, 1 bushing
 ø63: Supplied complete with 1 plate, 1 support, 1 pin, 2 bushings, 4 screws

DRIVE PIN

Code Ø A B ØC Weight [g]

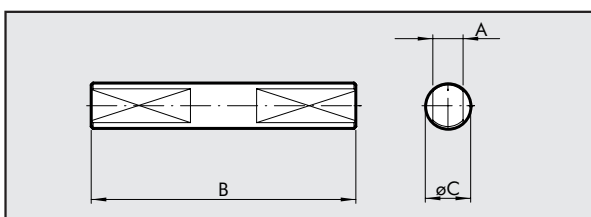

W0950167034	16	2.9	28	5	6
W0950257034	25	5	42	8	16
W0950327034	32	8	70	12	52
W0950327034	40	8	70	12	52
W0950637034	63	10	82	14	100

Note: Individually packed.

SWING SUPPORT Ø 16; 25

Code Ø A ØB C D E F Weight [g]

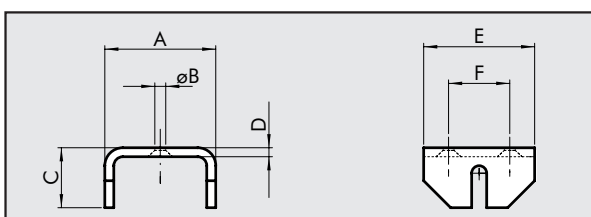

W0950167033	16	25	4.5	13	2	20	10	14
W0950257033	25	37	5.5	20	3	30	16	40

Note: Individually packed.

SWING SUPPORT Ø 32; 40; 63

Code Ø A ØB C D E F G Weight [g]

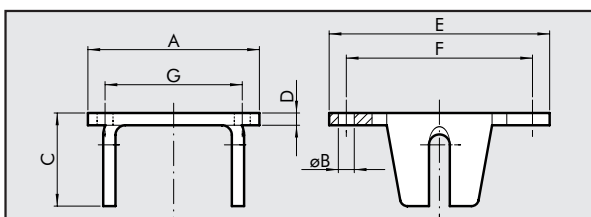

W0950327033	32	70	6.5	38	5	90	75	55	274
W0950327033	40	70	6.5	38	5	90	75	55	274
W0950637033	63	80	M8	32	8	80	65	37	400

Note: Individually packed.

SLIM SENSOR

Code Description

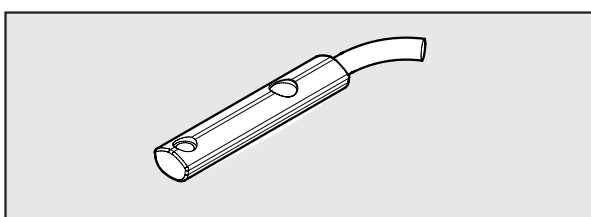

W0952025390	HALL N.O. SENSOR, VERTICAL INSERTION 2.5m
W0952029394	HALL N.O. SENSOR, VERTICAL INSERTION 300 mm M8
W0952022180	REED N.O. SENSOR, VERTICAL INSERTION 2.5m
W0952028184	REED N.O. SENSOR, VERTICAL INSERTION 300 mm M8

For technical data, refer to page 1.1/97

SENSOR SUPPORT Ø 16; 25

Code Description

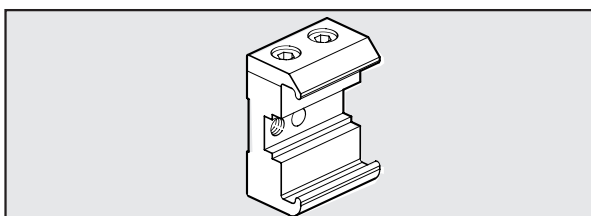

0950164001	SENSOR SUPPORT STD
------------	--------------------

Note: Supplied with 1 stud pin, 2 screws

BAR FOR GROOVING

Code Description

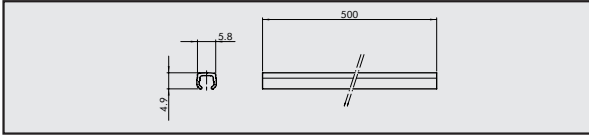

W0950000160 BAR FOR GROOVING L=500 mm

Note: the code corresponds to 1 piece

SLOTTED FIXING PLATE

Code Description Weight [g]

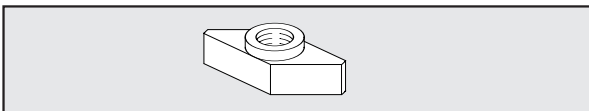

0950003001 ACC. M3 T-SLOTTED FIXING PLATE 1
0950003002 ACC. M4 T-SLOTTED FIXING PLATE 1

Note: Individually packed

ADJUSTABLE LIMIT SWITCH AND SHOCK ABSORBERS KIT

Code Description Weight [g]

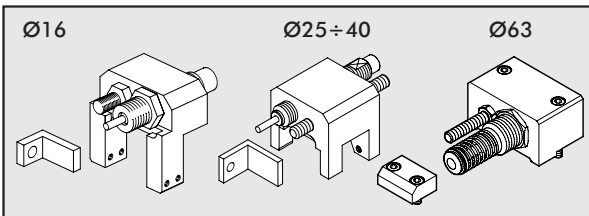

0950164002 ACC. RODLESS CYLINDER LIMIT SWITCH AND SHOCK ABSORBERS Ø 16 125
0950254002 ACC. RODLESS CYLINDER LIMIT SWITCH AND SHOCK ABSORBERS Ø 25 260
0950324002 ACC. RODLESS CYLINDER LIMIT SWITCH AND SHOCK ABSORBERS Ø 32 460
0950404002 ACC. RODLESS CYLINDER LIMIT SWITCH AND SHOCK ABSORBERS Ø 40 730
0950634002 ACC. RODLESS CYLINDER LIMIT SWITCH AND SHOCK ABSORBERS Ø 63 1620

Note: Supplied complete with 1 shock absorber support, 1 standard shock absorber, 1 shock absorber nut, 1 limit switch grub screw, 1 grub screw nut (2 for ø63), 1 bracket, 1 bracket screw, 4 locking grub screws (for Ø 16 and Ø 25), 4 locking plates and 4 screws (for Ø 32 and Ø 40).

SHOCK ABSORBERS

Code Bore Description

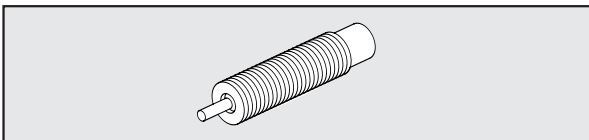

0950004003 ø16 Shock absorbers PRO15 MF1 + nut M12x1.5
0950004004 ø25 Shock absorbers PRO25 MC2 + nut M14x1.5
0950004005 ø32 Shock absorbers PRO50 MC2 + nut M20x1.5
0950004006 ø40 Shock absorbers PRO100 MF2 + nut M25x1.5
0950004007 ø63 Shock absorbers PRO125 MF3 + nut M36x1.5

GRAPHS TO HELP CHOOSE THE RIGHT SHOCK ABSORBERS

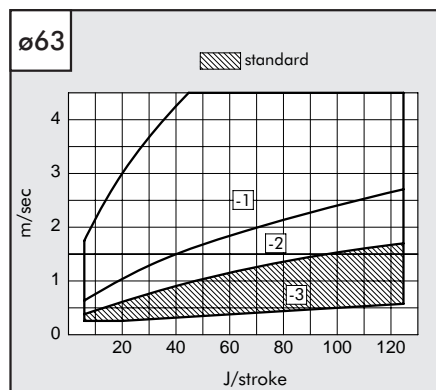
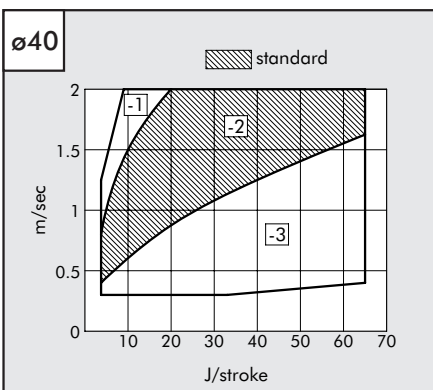
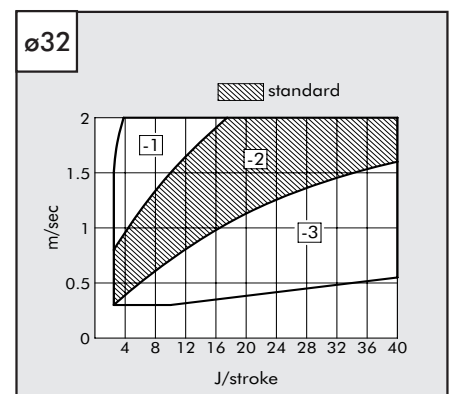
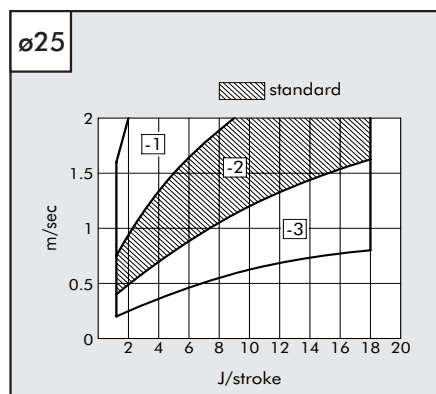
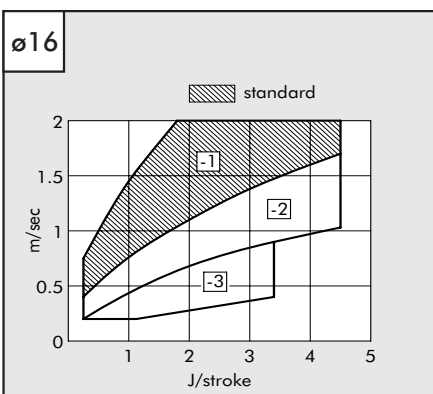

The dotted areas indicate that the SHOCK ABSORBERS is supplied standard. Other options can be selected depending on the speed [m/sec] and the maximum work force [J/stroke] to dissipate at each stroke. Refer to the diagrams above to select the correct option.

SPARE PARTS

"LAST RELEASE" CYLINDER

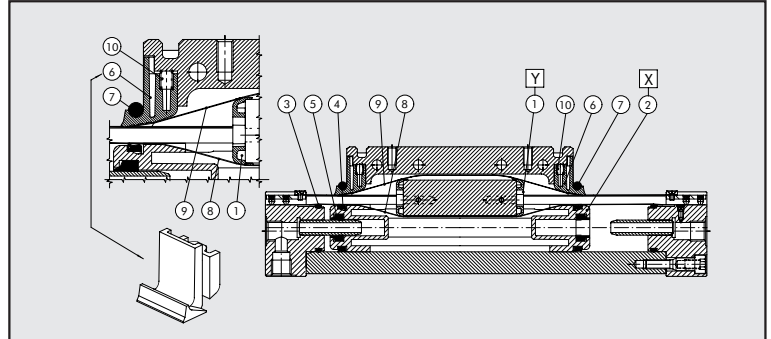
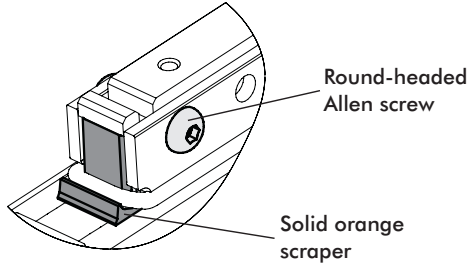

- ① Bands support Kit
- ② Piston kit
- ③ ④ ⑤ ⑥ ⑦ ⑩ NBR gaskets Kit (FKM/FPM for ⑦)
- ③ ④ ⑤ ⑥ ⑦ ⑩ FKM/FPM gaskets Kit
- ⑧ ⑨ Bands Kit (inner/outer)

Spare parts label on one cylinder side

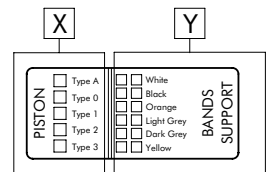

BANDS SUPPORT KIT POS 1 (Y)

Ø	Code White	Code Black	Code Orange	Code Light grey	Code Dark grey	Code Yellow
16	0090165080	0090165081	0090165082	0090165083	0090165084	0090165085
25	0090255080	0090255081	0090255082	0090255083	0090255084	0090255085
32	0090325080	0090325081	0090325082	0090325083	0090325084	0090325085
40	0090405080	0090405081	0090405082	0090405083	0090405084	0090405085
63	*0090635080	*0090635081	*0090635082	*0090635083	*0090635084	*0090635085

BANDS KIT (inner and outer) pos 8-9

Ø	Code	
16	0090166...	
25	0090256...	
32	0090326...	
40	0090406...	
63	0090636...	...= STROKE

* For ø63, the kit includes a strip support and a shim in the colour ordered. Therefore, two kits must be ordered for each cylinder.

NBR GASKET KIT posn. 3,4,5,6,7,10

Ø	Code
16	0090165022
25	0090255022
32	0090325022
40	0090405022
63	0090635022

FKM/FPM GASKET KIT posn. 3-4-5-6-7-10

Ø	Code
16	0090165023
25	0090255023
32	0090325023
40	0090405023
63	0090635023

PISTON KIT POS 2 (X)

Ø	Code		Code		Code	
	Type 0 (0 rings)	Type 1 (1 rings)	Type 2 (2 rings)	Type 3 (3 rings)	Type A (4 rings)	
16	0090165015	0090165016	0090165017	0090165018	-	
25	0090255015	0090255016	0090255017	0090255018	-	
32	0090325015	0090325016	0090325017	0090325018	0090325019	
40	0090405015	0090405016	0090405017	0090405018	-	
63	0090635015	0090635016	0090635017	0090635018	-	

NOTES

IF THE ENDS OF THE CARRIAGE APPEAR AS BELOW INDICATED, PLEASE CONTACT OUR COMMERCIAL DEPARTMENT FOR THE SPARE PARTS

"INTERMEDIATE RELEASE"

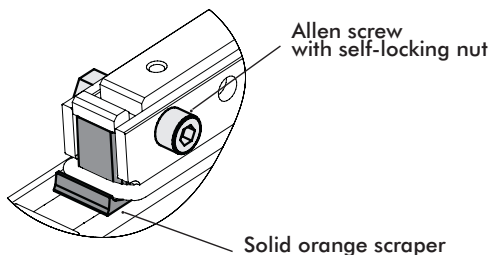

"OLD RELEASE"

