

# CYLINDER SERIES ISO 6431 VDMA, Ø 32-63 mm TWO-FLAT

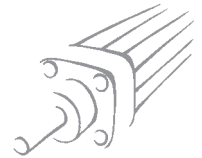

1

This version of cylinder is used to keep the parts fixed to the piston rod at an angle and to apply torques within the specified limits.

The piston rod of the Two Flat has two opposing longitudinal surfaces; it is made of stainless steel.

The front cylinder head includes a sintered bronze bush that matches the profile of the piston rod and prevents it from rotating on its own axis. A special polyurethane gasket ensures pneumatic seal and prevents the accumulation of dirt. This technical solution is more reliable and gives a better pneumatic seal than with square or hexagonal piston rods. The cylinders are made to ISO 6431, ISO15552 and VDMA standards. They are available in several versions and with a wide range of accessories:

- with or without magnet
- double acting, single piston rod
- double acting, through rod; one piston rod is Two Flat, the other cylindrical
- fixing accessories.



TECHNICAL DATA	POLYURETHANE
Operating pressure	max 10 bar (max 1 MPa - 145 psi)
Temperature range	-20 ÷ +80 (non-magnetic cyl.) -20 ÷ +70 (magnetic cyl.)
Fluid	Unlubricated air. Lubrication, if used, must be continuous
Bore	Ø 32 ; Ø 40 ; Ø 50 ; Ø 63
Design	Heads with Tap Tite screws
Maximum stroke	mm Ø 32= 300    Ø 40= 400    Ø 50= 500    Ø 63= 500
Versions	Double-acting cushioned, Through-rod cushioned, no-stick slip*
Sensor magnet	All versions come complete with magnet. Supplied without magnet on request.
Inrush pressure	Ø 32= 0.4    Ø 40= 0.4    Ø 50= 0.3    Ø 63= 0.3
Max torque on piston rod	Nm Ø 32= 0.2    Ø 40= 0.4    Ø 50= 1    Ø 63= 1
Maximum rotation on the rod	degrees Ø 32= 0.70°    Ø 40= 0.75°    Ø 50= 0.65°    Ø 63= 0.65°
Forces generated at 6 bar thrust/retraction	See GENERAL TECHNICAL DATA PAGE 1.1/05
Weights	See GENERAL TECHNICAL DATA PAGE 1.1/06
	*For no-stick slip versions, use no-lubricated air only

## COMPONENTS

- ① PISTON ROD: stainless steel.
- ② HEAD: die cast aluminium, fully machined
- ③ PISTON ROD GASKET: polyurethane (PARKER PRADIFA)
- ④ GUIDE BUSHING: sintered bronze
- ⑤ BARREL: drawn anodised calibrated aluminium
- ⑥ HALF-PISTON: self-lubricating technopolymer with built-in cushioning olives
- ⑦ PISTON GASKET: Ø 32÷63 polyurethane (PARKER PRADIFA)
- ⑧ MAGNET: plastoferrite
- ⑨ Static O-rings: NBR
- ⑩ CUSHIONING GASKET: polyurethane (PARKER PRADIFA)
- ⑪ CUSHIONING NEEDLE: OT 58 with needle out movement safety system even when fully open
- ⑫ SCREWS: Tap Tite for assembly

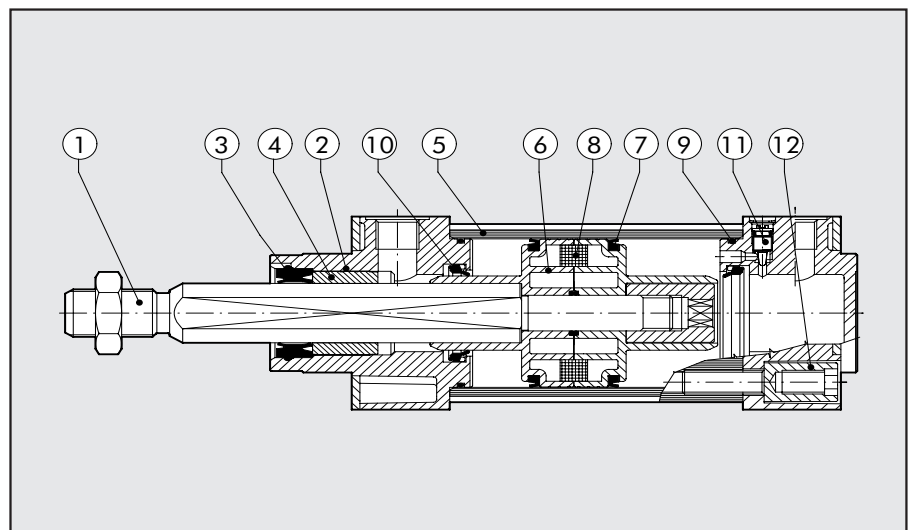

### DIMENSIONS OF STANDARD VERSIONS

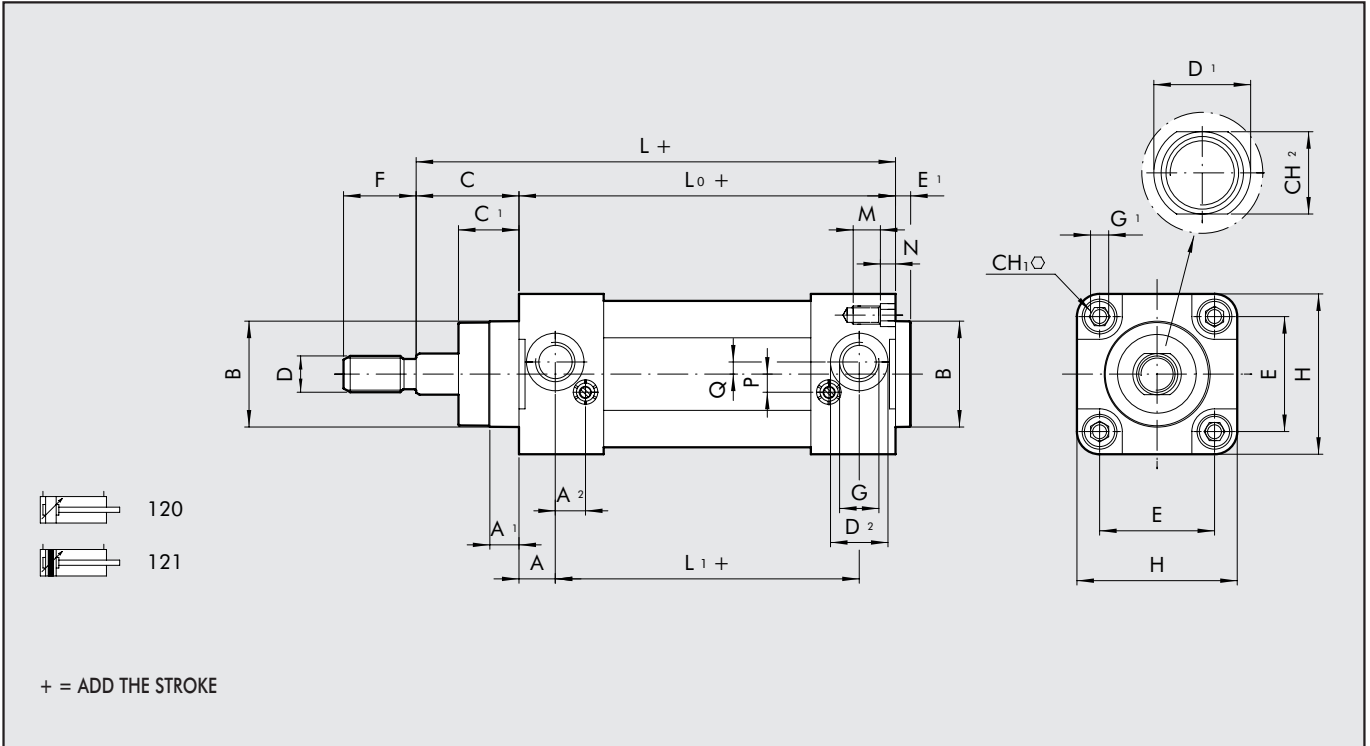

### DIMENSIONS OF THROUGH-ROD VERSION

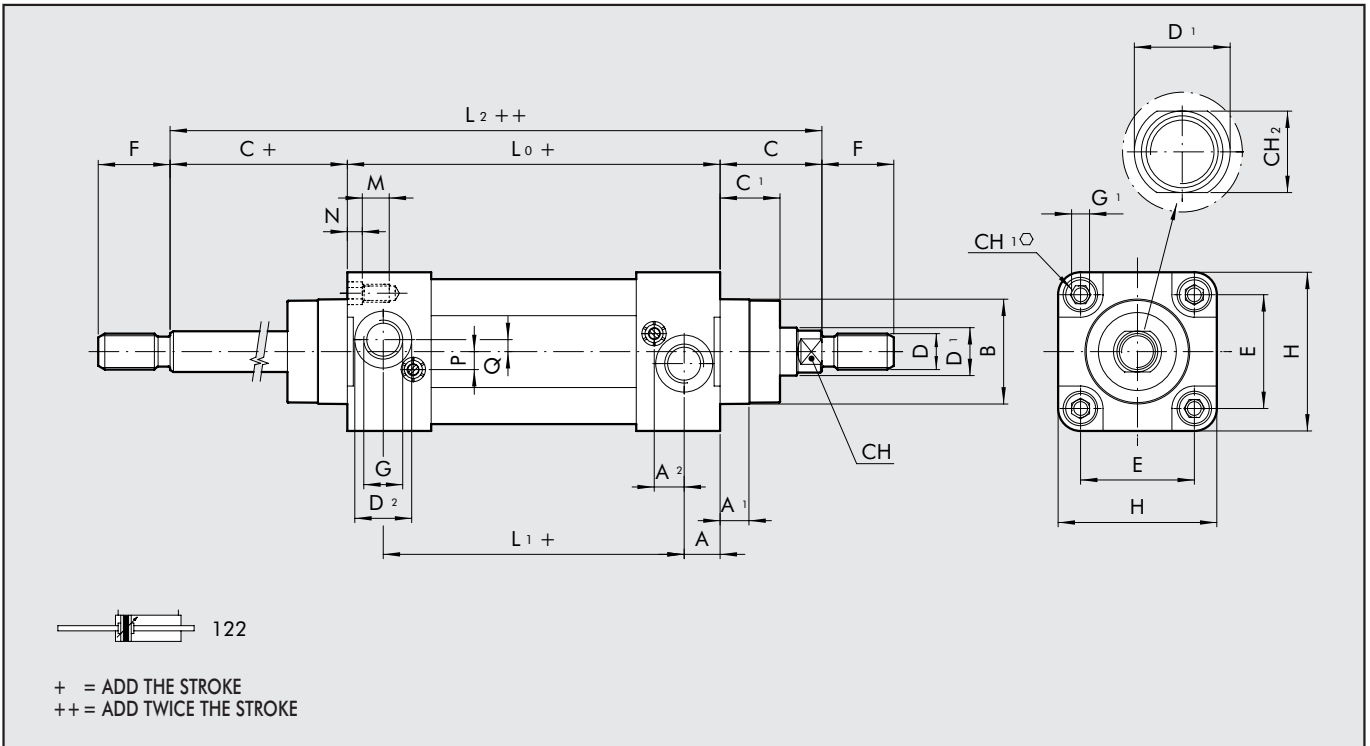

Ø.	A	A <sub>1</sub>	A <sub>2</sub>	B	C	C <sub>1</sub>	CH	CH <sub>1</sub>	CH <sub>2</sub>	D	D <sub>1</sub>	D <sub>2</sub>	E	E <sub>1</sub>	F	G	G <sub>1</sub>	H	L	L <sub>0</sub>	L <sub>1</sub>	L <sub>2</sub>	M	N	P	Q
32	10	7	10	30	26	16	10	6	10	M10x1.25	12	15	32.5	5	22	G1/8	M6	47	120	94	74	146	9	4.5	6	4
40	12	9	10	35	30	20	13	6	13	M12x1.25	16	19	38	5	24	G1/4	M6	53	135	105	81	165	9	4.5	6	4
50	14	14	10	40	37	25	17	8	17	M16x1.5	20	19	46.5	5	32	G1/4	M8	65	143	106	78	180	12	5.5	6	6
63	16	14	10	45	37	25	17	8	17	M16x1.5	20	23	56.5	5	32	G3/8	M8	75	158	121	89	195	12	5.5	6	6



KEY TO CODES

CYL	1	2	1	0	3	2	0	0	5	0	F	P		
	TYPE				BORE		STROKE							
120	Double-acting, cushioned, non-magnetic			0 Diameter	32	40	Ø32	stroke 0÷300 mm				F	"Two Flat" piston rod AISI 303 stainless steel nut	P polyurethane gaskets
121	Double-acting, cushioned			S Non-magnetic	50	63	Ø40	stroke 0÷400 mm						
122	Through-rod			G No stick slip			Ø50÷Ø63	stroke 0÷500 mm						

ACCESSORIES: FIXINGS

INTERMEDIATE HINGE - MODEL EN

Code	Ø	A <sub>3 (min)</sub>	A <sub>7</sub>	A <sub>8 (max)</sub>	N <sub>1</sub>	N <sub>2</sub>	N <sub>3 e 9</sub>	N <sub>4</sub>	N <sub>5</sub>	Weight [g]
------	---	----------------------	----------------	----------------------	----------------	----------------	--------------------	----------------	----------------	------------

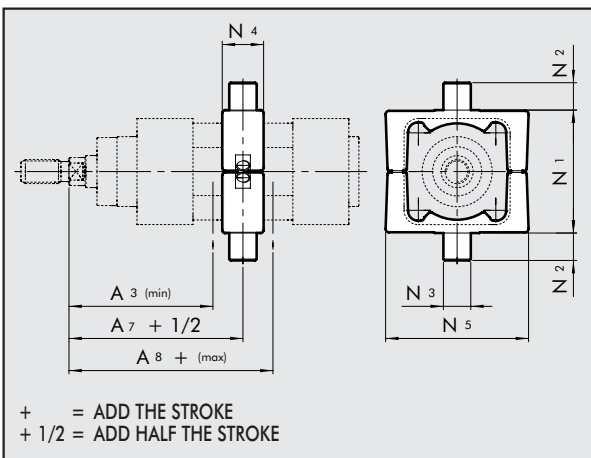

0950322007	32	63	73	83	50	12	12	22	65	282
0950402007	40	72	82.5	93	63	16	16	28	75	582
0950502007	50	83	90	97	75	16	16	32	95	880
0950632007	63	86.5	97.5	108.5	90	20	20	35	105	1230

Note: Supplied complete with 4 grub screws, 2 pins

COUNTER-HINGE FOR MODEL EN - MODEL EL

Cod.	Ø	A	A <sub>1</sub>	B	C	C <sub>1</sub>	D <sub>1</sub>	D <sub>2</sub>	D	E	H	ØL	Weight [g]
------	---	---	----------------	---	---	----------------	----------------	----------------	---	---	---	----	------------

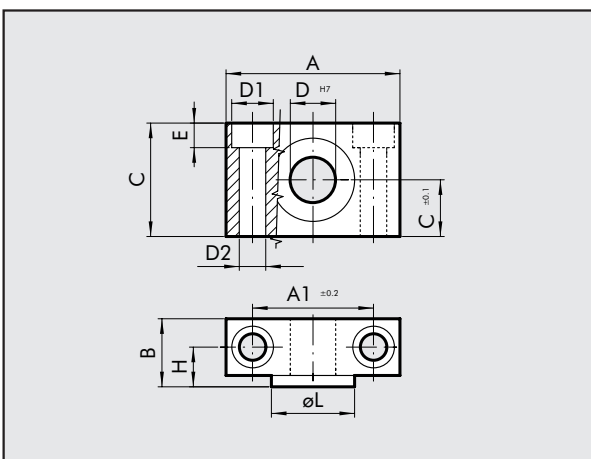

W0950322009	32	46	32	18	30	15	11	7	12	6.5	10.5	22	162
W0950402009	40	55	36	21	36	18	15	9	16	8.5	12	28	278
W0950402009	50	55	36	21	36	18	15	9	16	8.5	12	28	278
W0950632009	63	65	42	23	40	20	18	11	20	10.5	13	35	414

NOTE: Supplied with 4 securing screws

### CYLINDER BRACKET - VALVE SERIES KCV

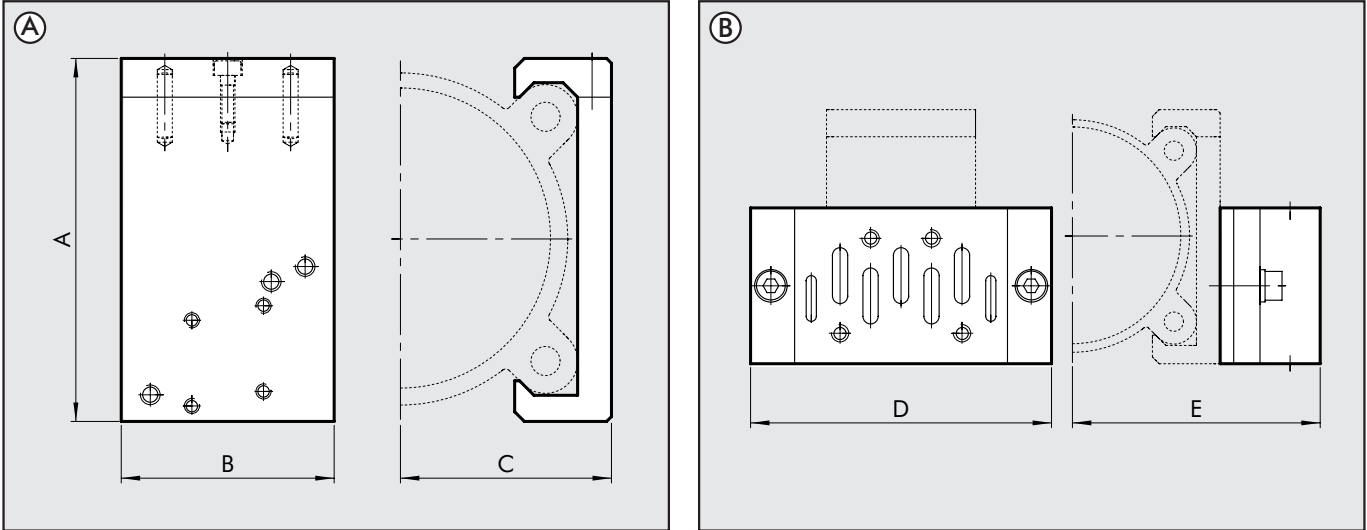

### VALVE FIXING BRACKET - CYLINDER (Fig. A)

Code	Ø	A	B	C	ISO 1		ISO 2		Applicable valves	Weight (g)
					D	E	D	E		
0950322090	Ø 32	54	40	29.5	110	64.5	124	70.5	MACH 16 Series 70 1/8-1/4 ISO 1 - ISO 2	80
0950402090	Ø 40	59.5	40	32.2	110	67.2	124	73.2	MACH 16 Series 70 1/8-1/4 ISO 1 - ISO 2	86
0950502090	Ø 50	71.5	40	37	110	72	124	78	MACH 16 Series 70 1/8-1/4 ISO 1 - ISO 2	93
0950632090	Ø 63	81.5	40	42	110	77	124	83	MACH 16 Series 70 1/8-1/4 ISO 1 - ISO 2	101

### KIT FOR FIXING VALVES TO BRACKETS

Code	Valve kit	Composition	Weight (g)
0950002003	MACH 16	2 HEX. SCREWS M3x25 with WASHER	4
0950002004	Series 70 1/8-1/4	2 HEX. SCREWS M4x50 with WASHER	8
0950002006	Series 70 1/2	2 HEX. SCREWS M5x50 with WASHER	20
0950002001	ISO 1	ADAPTOR + ISO 1 BASE SIDE + SCREWS + WASHERS (Fig. B)	230
0950002002	ISO 2	ADAPTOR + ISO 2 BASE SIDE + SCREWS + WASHERS (Fig. B)	350

### VALVE ASSEMBLY ON CYLINDER

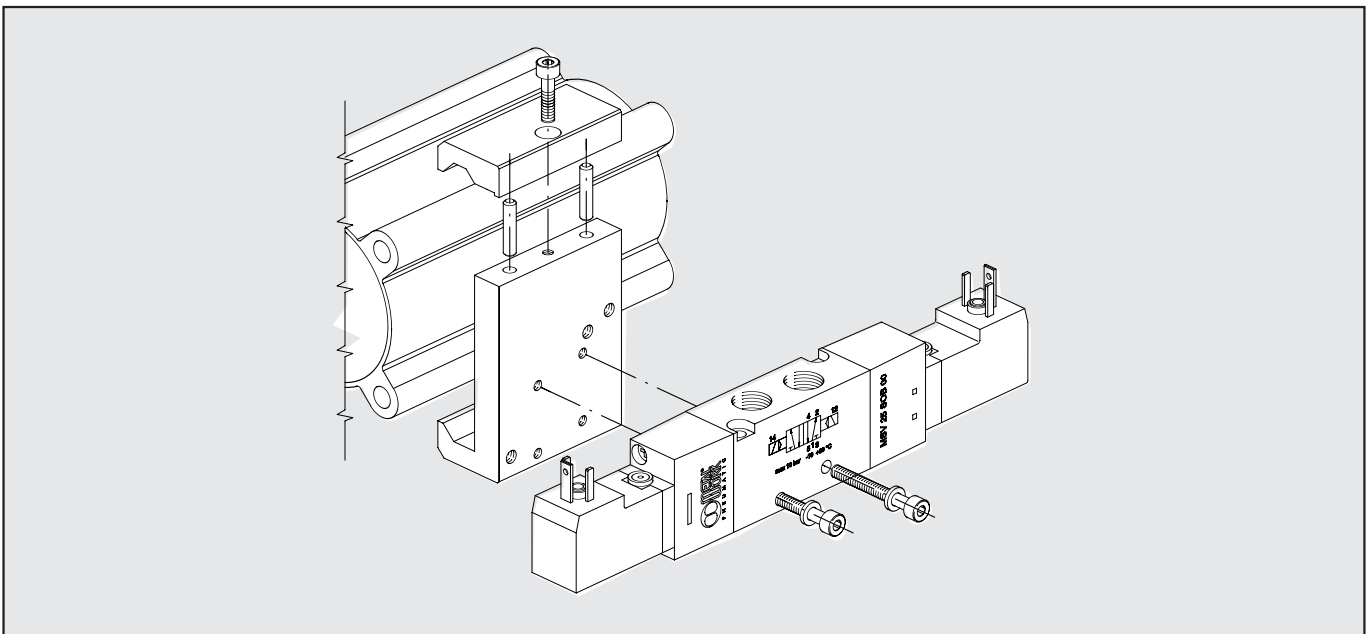

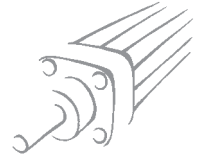

# ACCESSORIES: MAGNETIC SENSORS

1

## SENSOR

Code	Description
W0950000201	SENSOR REED DSM2-C525
W0950000222	SENSOR HALL PNP DSM3-N225
W0950000232	SENSOR HALL NPN DSM3-M225

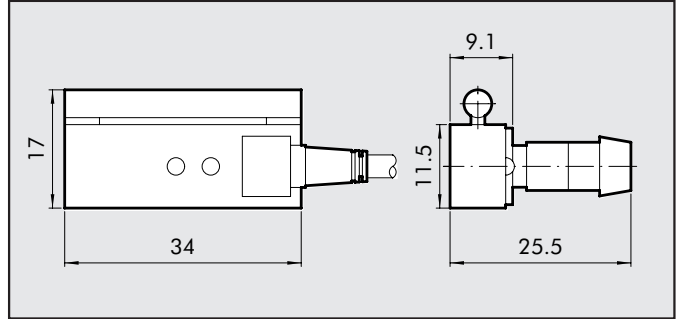

## SENSOR BRACKETS

Code	Description
W0950000711	BRACKET ACC. D.32 DST 80
W0950000712	BRACKET ACC. D.50 DST 81

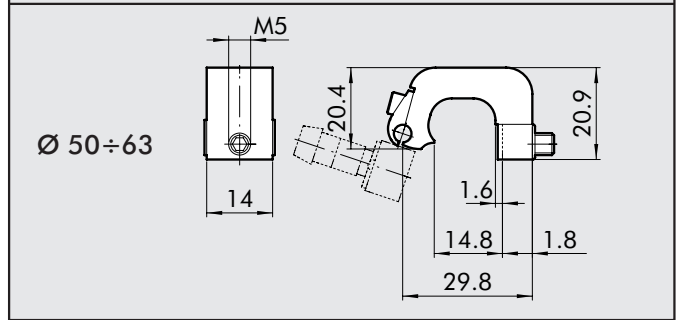
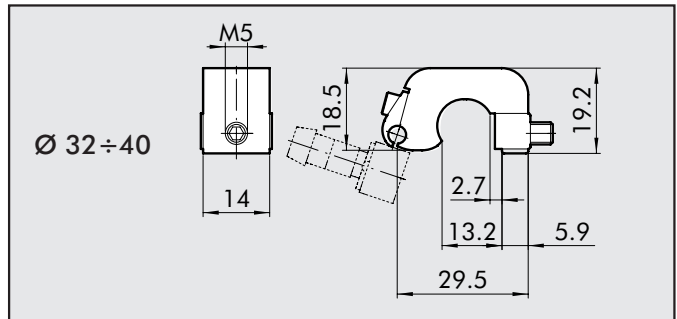

## TECHNICAL DATA

Type		REED+VARISTOR+LED 2 wires	HALL VERSION PNP/NPN 3 wires
Contact		REED+VARISTOR+LED NO	HALL EFFECT NO PNP/NPN
Max AC/DC voltage	V	3÷48V (DC) 3÷220 (AC)	6-24 V DC
Max current at 25°C	mA	500	250
Power with inductive load	VA	10	-
Power with resistive load	Watt	50	6
Switch-on time	m sec	1.2	0.8
Switch-off time	m sec	0.1	3
Switch-on point	Gauss	110	15
Switch-off point	Gauss	95	8
Operating life	-	10 <sup>7</sup> impulses	10 <sup>9</sup> impulses
Contact resistance		0.1	-
Cable length	m	2.5	2.5
Cable cross section	mm <sup>2</sup>	0.35	0.35
Cable material		Soft PVC	Soft PVC
Circuit0			

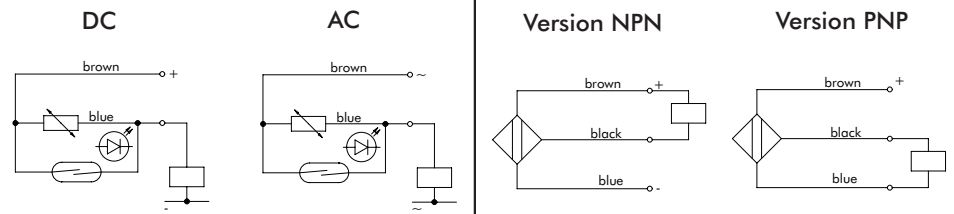





**DIMENSIONS OF STANDARD VERSIONS**

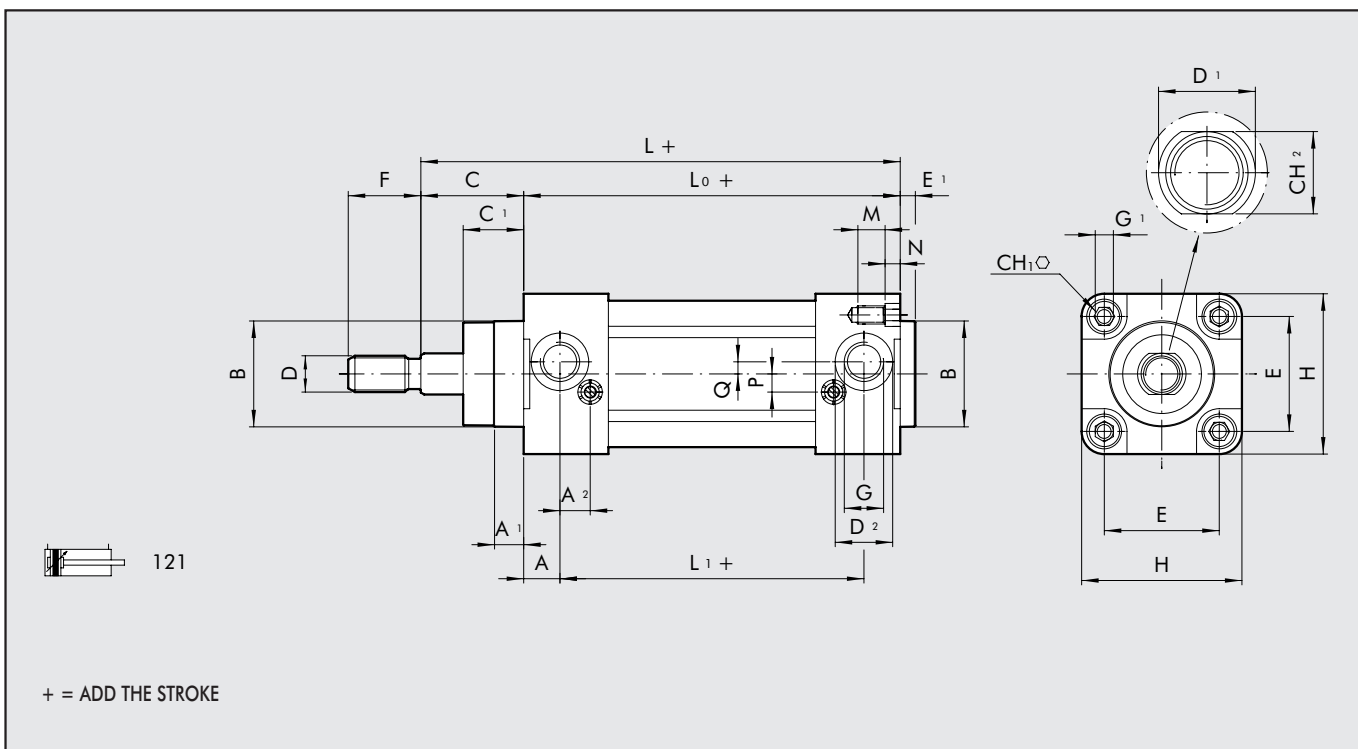

**DIMENSIONS OF THROUGH-ROD VERSION**

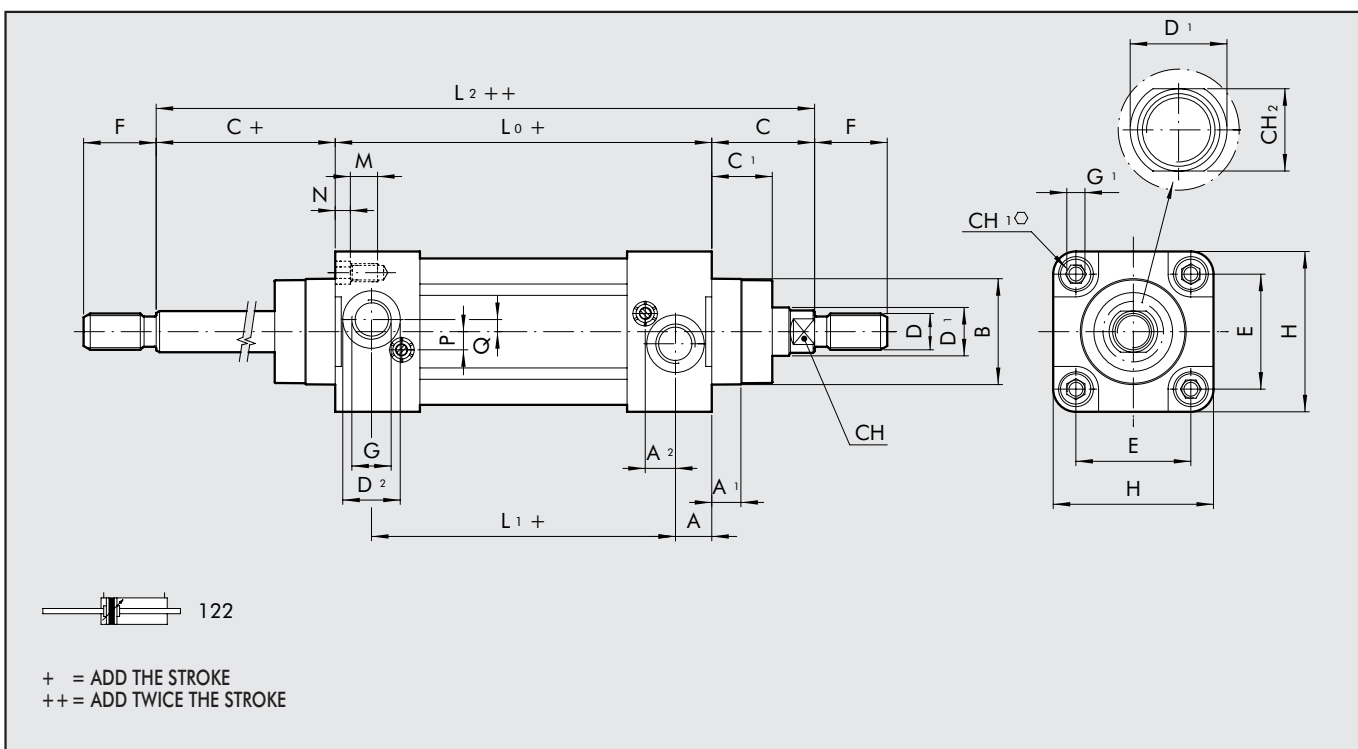

Ø	A	A <sub>1</sub>	A <sub>2</sub>	B	C	C <sub>1</sub>	CH	CH <sub>1</sub>	CH <sub>2</sub>	D	D <sub>1</sub>	D <sub>2</sub>	E	E <sub>1</sub>	F	G	G <sub>1</sub>	H	L	L <sub>0</sub>	L <sub>1</sub>	L <sub>2</sub>	M	N	P	Q
32	10	7	10	30	26	16	10	6	10	M10x1.25	12	15	32.5	5	22	G1/8	M6	47	120	94	74	146	9	4.5	6	4
40	12	9	10	35	30	20	13	6	13	M12x1.25	16	19	38	5	24	G1/4	M6	53	135	105	81	165	9	4.5	6	4
50	14	14	10	40	37	25	17	8	17	M16x1.5	20	19	46.5	5	32	G1/4	M8	65	143	106	78	180	12	5.5	6	6
63	16	14	10	45	37	25	17	8	17	M16x1.5	20	23	56.5	5	32	G3/8	M8	75	158	121	89	195	12	5.5	6	6

### KEY TO CODES

CYL	1	2	1	A	3	2	0	0	5	0	F	P	
	TYPE			DIAMETER			STROKE						
121	Double-acting, cushioned			A	Standard	32	Ø32	stroke 0÷300 mm			F	"Two Flat" piston rod AISI 303 stainless steel nut	P polyurethane gaskets
122	Through-rod			B	No stick slip	40	Ø40	stroke 0÷400 mm					
				C	Non-magnetic	50 63	Ø50÷Ø63	stroke 0÷500 mm					

### VALVE ASSEMBLY ON CYLINDER

With this type of cylinder, the valves (D) can be mounted directly using the retracting sensor slot, without requiring the use of intermediate brackets.

This can be done using the special plates (A), which come with both the M3 and M4 threads, and screws (B) of the size, type and quantity shown in the table below.

For ISO 1 and ISO 2 valves, the kit on which the valve is to be mounted (codes shown in the tables) will be fitted to the cylinder using the special plates (A) and the screws (B) listed in the table.

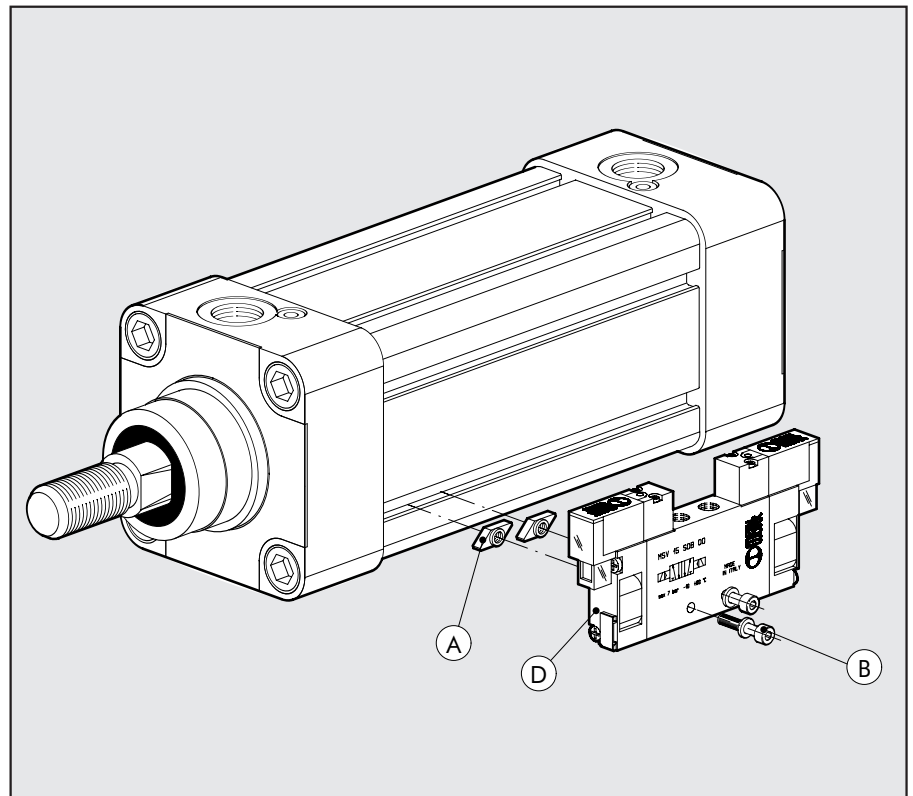

Type of valve to mount (D)	M3 fixing plate (A) code 0950003002	M4 fixing plate (A) code 0950003001	Screw (B) for connection to cylinder (one per plate)	Washer (B) (one per screw)	Valve assembly kit
MACH 11	n° 2	-	M3x16 UNI 5931 (DIN 912)	A3.2 UNI 1751 (DIN 127A)	-
SERIE 70 1/8	-	n° 2	M4x25 UNI 5931 (DIN 912)	-	-
SERIE 70 1/4	-	n° 2	M4x30 UNI 5931 (DIN 912)	A4.3 UNI 1751 (DIN 127A)	-
SERIE 70 1/2	-	n° 2	M4x45 UNI 5931 (DIN 912)	A4.3 UNI 1751 (DIN 127A)	-
ISO 1	-	n° 2	M4x8 UNI 7688 (DIN 965A)	-	0950002001
ISO 2	-	n° 2	M4x8 UNI 7688 (DIN 965A)	-	0950002002

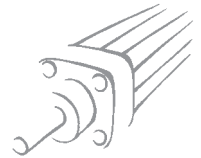

# ACCESSORIES: MAGNETIC SENSORS

1

## RETRACTABLE SENSOR WITH INSERTION FROM ABOVE

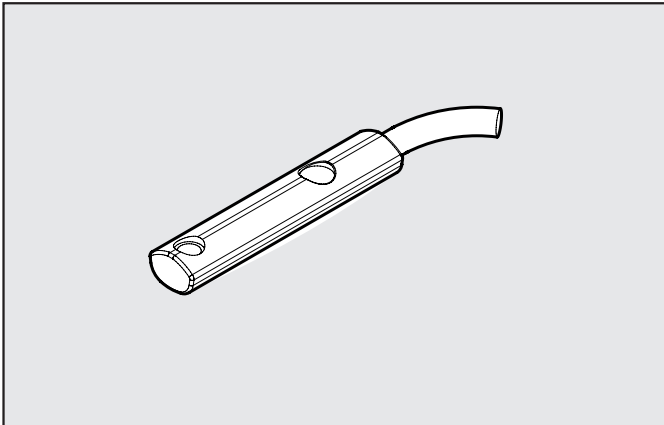

Code	Description
W0952025390	HALL N.O. SENSOR, VERTICAL INSERTION 2.5m
W0952029394	HALL N.O. SENSOR, VERTICAL INSERTION 300 mm M8
W0952022180	REED N.O. SENSOR, VERTICAL INSERTION 2.5m
W0952028184	REED N.O. SENSOR, VERTICAL INSERTION 300 mm M8

This type of sensor can be inserted in the slot of the sensor from above. This means the cylinder heads do not require a through opening.

## WIRING DIAGRAM

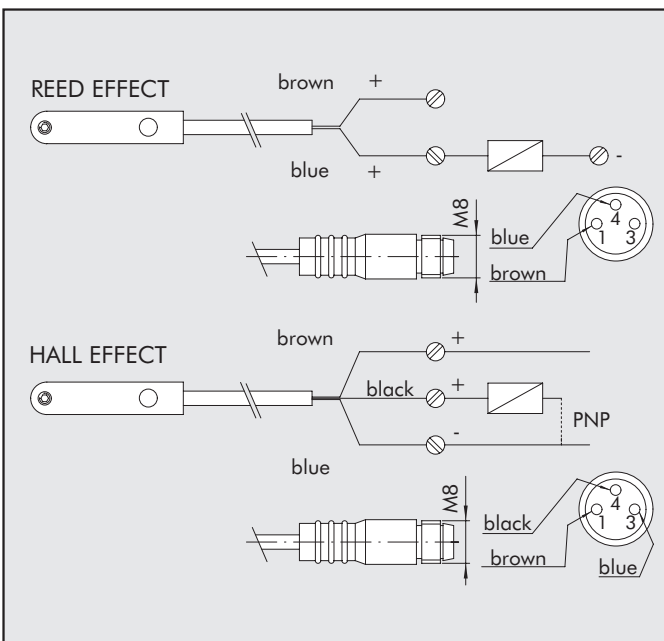

## TECHNICAL DATA

	Reed	Effetto Hall
Type of contact	N.O.	N.O.
Switch	-	PNP
Supply voltage (U <sub>b</sub> )	V 10 ÷ 30 AC/DC	10 ÷ 30 DC
Power	W 3 (peak valve=6)	3
Voltage variation	-	≤ 10% di U <sub>b</sub>
Voltage drop	V -	≤ 2
Input current	mA -	≤ 10
Output current	mA ≤ 100	≤ 100
Switching frequency	Hz ≤ 400	≤ 5
Short-circuit protection	-	Yes
Over-voltage suppression	-	Yes
Polarity inversion protection	-	Yes
EMC	EN 60 947-5-2	EN 60 947-5-2
LED display	Yellow	Yellow
Magnetic sensitivity	2,8 mT ±25%	2,8 mT ±25%
Repeatability	≤ 0,1 mT	≤ 0,1 mT
Degree of protection (EN 60529)	IP 67	IP 67
Vibration and shock resistance	30 g, 11 ms, 10÷55 Hz, 1mm	30 g, 11 ms, 10÷55 Hz, 1mm
Temperature range	°C -25 ÷ +75	-25 ÷ +75
Sensor capsule material	PA66 + PA6I/6T	PA66 + PA6I/6T
2.5m connecting cable	PVC; 2 x 0,12 mm <sup>2</sup>	PVC; 3 x 0,14 mm <sup>2</sup>
Connecting cable with M8x1	Polyurethane; 2 x 0,14 mm <sup>2</sup>	Polyurethane; 3 x 0,14 mm <sup>2</sup>

## STRIP

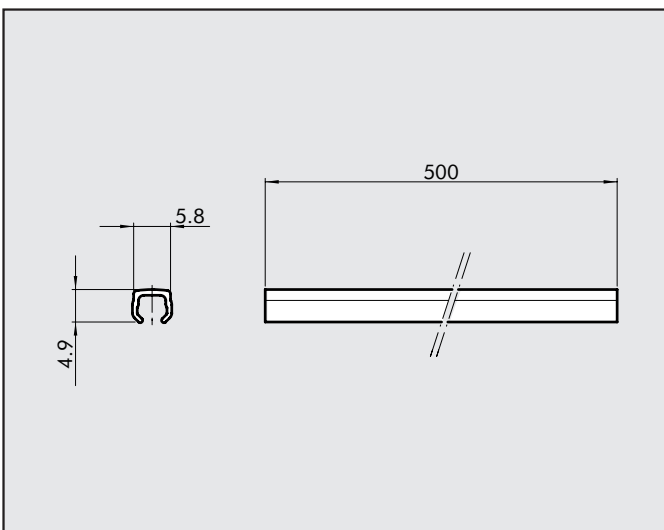

Code	Description
W0950000160	SLOT STRIP 500 mm

Note: The code corresponds to 1 piece.

# ACCESSORIES ISO 6431 STD AND TYPE "A" RETRACTABLE SENSOR TWO-FLAT: FIXINGS

## LEGS - MODEL A

Code      Ø      Ø AB      AH      AO      AT      AU      TR      UH      H<sub>1</sub>      H<sub>2</sub>      Weight [g]

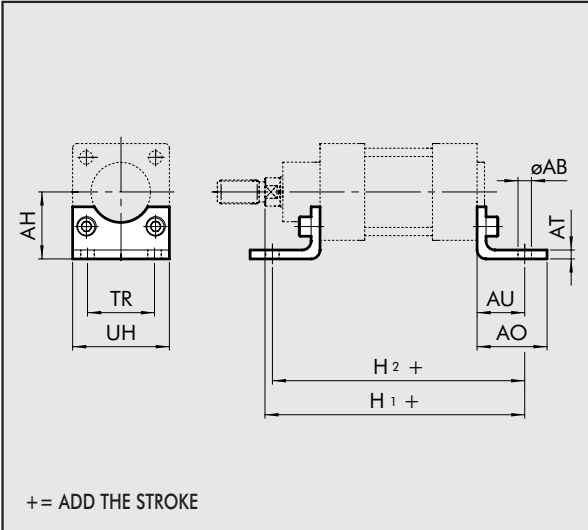

W0950322001	32	7	32	35	4	24	32	45	144	142	76
W0950402001	40	9	36	43	4	28	36	52	163	161	100
W0950502001	50	9	45	47	4	32	45	65	175	170	162
W0950632001	63	9	50	47	6	32	50	75	190	185	266

Note: Individually packed with 2 screws.

## FEMALE HINGE - MODEL B

Code      Ø      B      D      E      Ø G      H<sub>3</sub>      R      S      Weight [g]

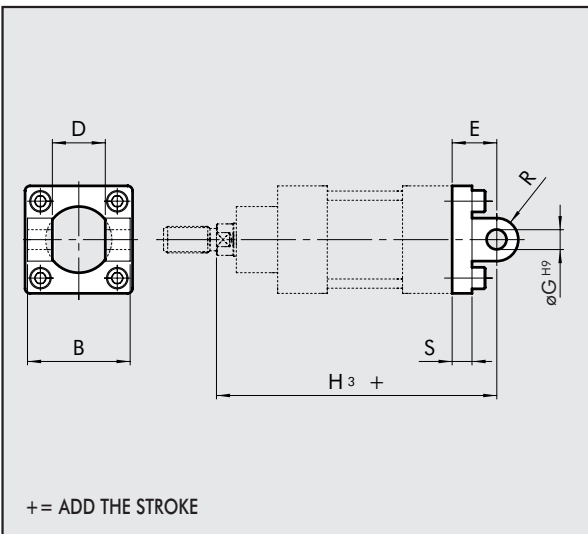

W0950322003	32	45	26	22	10	142	11	10	116
W0950402003	40	52	28	25	12	160	13	10	160
W0950502003	50	60	32	27	12	170	13	12	252
W0950632003	63	70	40	32	16	190	17	12	394

Note: Supplied with 4 screws, 4 washers, 2 snap-rings, 1 pin.

## MALE HINGE - MODEL BA

Code      Ø      D      E      F      Ø G      H      H<sub>3</sub>      Weight [g]

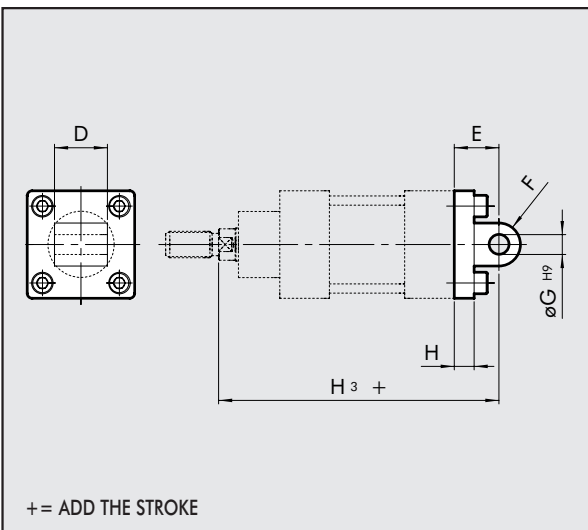

W0950322004	32	26	22	11	10	10	142	94
W0950402004	40	28	25	13	12	10	160	124
W0950502004	50	32	27	13	12	12	170	220
W0950632004	63	40	32	17	16	12	190	316

Note: Supplied with 4 screws, 4 washers



**ARTICULATED MALE HINGE - MODEL BAS**

Code	Ø cil.	E	F	H	H <sub>3</sub>	M	N	Weight [g]
W0950322006	32	22	16	10	142	10	14	106
W0950402006	40	25	19	10	160	12	16	142
W0950502006	50	27	19	12	170	12	16	236
W0950632006	63	32	24	12	190	16	21	336

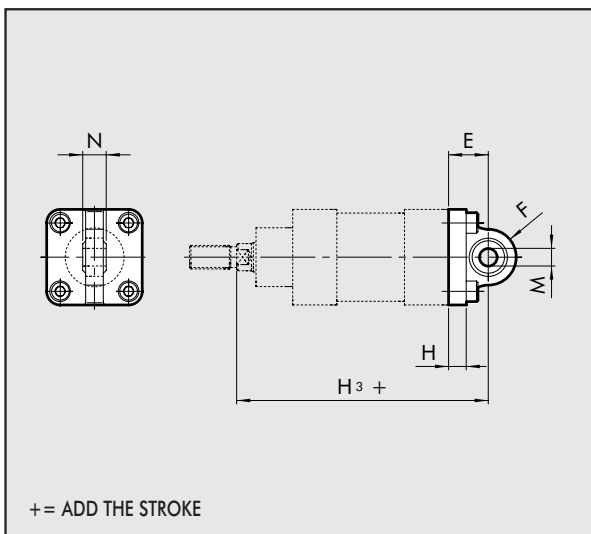

Note: Supplied with 4 screws, 4 washers

**CETOP COUNTER-HINGE FOR MODEL B MODEL GL**

Code	Ø	A	B	C	D	E	F	G	H	I	L	M	N	Weight [g]
W0950322008	32	26	19	7	10	25	20	32	37	41	18	8	10	96
W0950402008	40	28	26	9	12	32	32	45	54	52	25	10	12	216
W0950502008	50	32	26	9	12	32	32	45	54	52	25	10	12	212
W0950632008	63	40	33	11	16	40	50	63	75	63	32	12	15	440

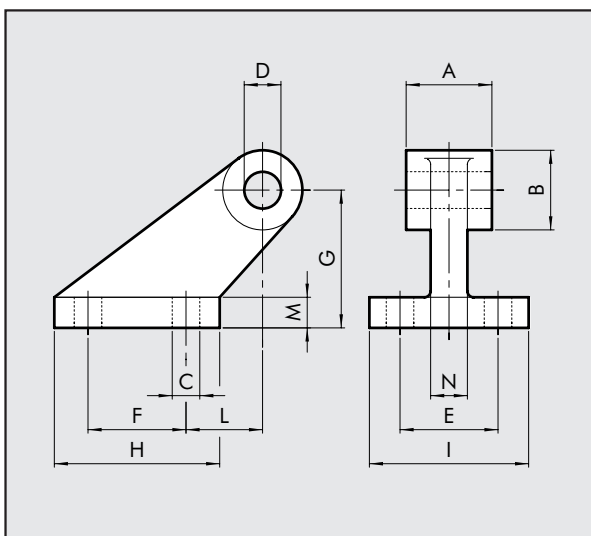

Note: Supplied with 4 screws, 4 washers

**ISO COUNTER-HINGE FOR MODEL B MODEL GS**

Code	Ø	B	C	D	E	G	J	L	M	N	Weight [g]
W0950322108	32	25.5	32.5	45	7	32	11	10	10	10	106
W0950402108	40	27.5	38	52	7	36	13	10	12	12	138
W0950502108	50	31.5	46.5	65	9	45	13	12	12	12	252
W0950632108	63	39.5	56.5	75	9	50	17	16	12	15	350

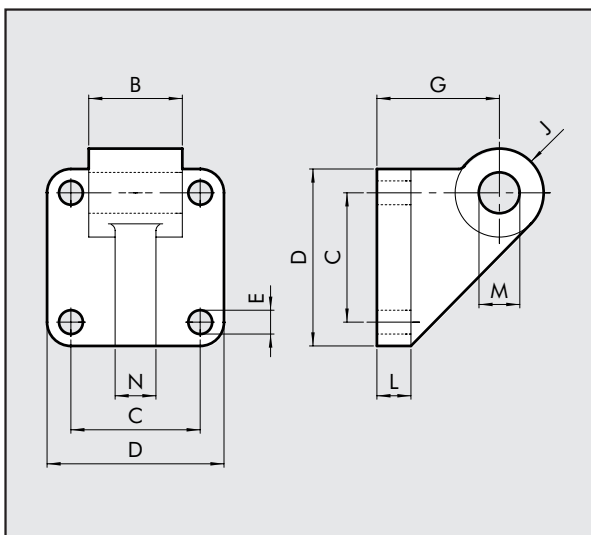

Note: Supplied with 4 screws, 4 washers

### FRONT FLANGE - MODEL C

Code	Ø	A <sub>1</sub>	A	B	S	B <sub>1</sub>	ØD <sub>4</sub>	W	Weight [g]
------	---	----------------	---	---	---	----------------	-----------------	---	------------

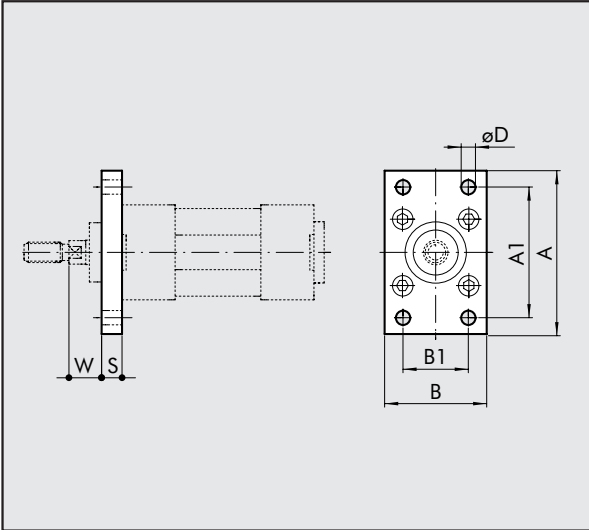

W0950322002	32	64	80	50	10	32	7	16	246
W0950402002	40	72	90	55	10	36	9	20	290
W0950502002	50	90	110	65	12	45	9	25	522
W0950632002	63	100	120	75	12	50	9	25	670

Note: Supplied with 4 screws.

### REAR FLANGE - MODEL C

Code	Ø	A <sub>1</sub>	A	B	S	B <sub>1</sub>	ØD <sub>4</sub>	L+corsa	Weight [g]
------	---	----------------	---	---	---	----------------	-----------------	---------	------------

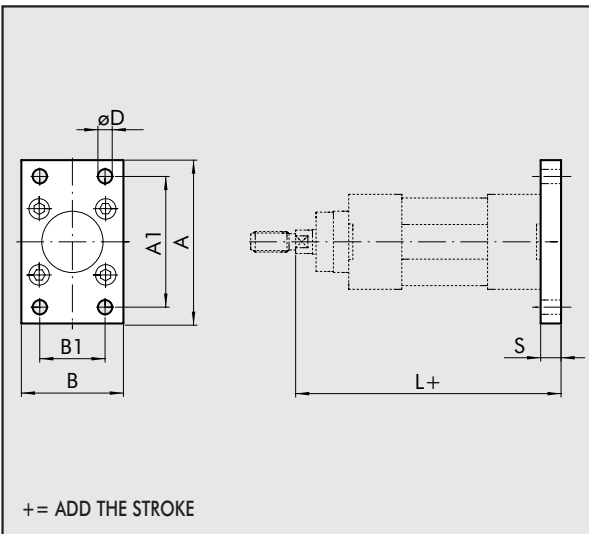

W0950322002	32	64	80	50	10	32	7	130	246
W0950402002	40	72	90	55	10	36	9	145	290
W0950502002	50	90	110	65	12	45	9	155	522
W0950632002	63	100	120	75	12	50	9	170	670

Note: Supplied with 4 screws.

### NUT FOR PISTON RODS - MODEL S

Code	Ø	F	H	CH	Weight [g]
------	---	---	---	----	------------

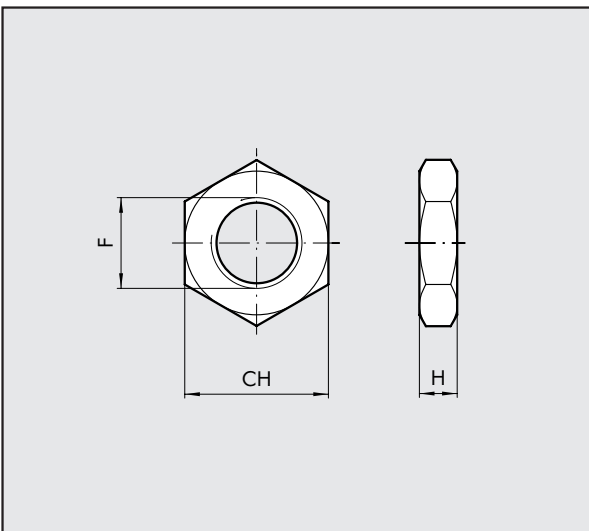

0950320200	32	M10x1.25	6	17	6
0950400200	40	M12x1.25	7	19	12
0950500200	50/63	M16x1.5	8	24	20

Note: Individually packed.



**FORK MODEL GK-M**

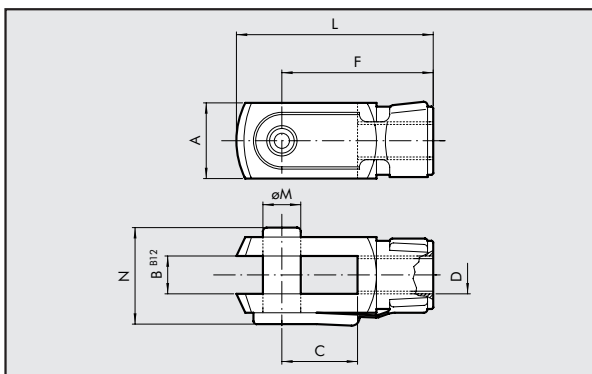

Code	Ø	Ø M	C	B	A	L	F	D	N	Weight [g]
W0950322020	32	10	20	10	20	52	40	M10x1.25	26	92
W0950402020	40	12	24	12	24	62	48	M12x1.25	32	148
W0950502020	50	16	32	16	32	83	64	M16x1.5	40	340
W0950502020	63	16	32	16	32	83	64	M16x1.5	40	340

Note: Individually packed.

**ARTICULATED JOINT - MODEL GA-M**

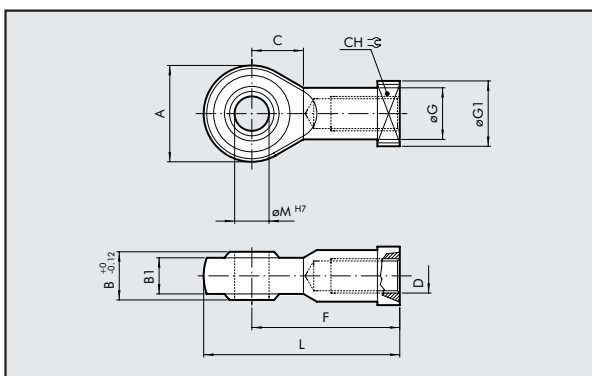

Code	Ø	Ø M	C	B1	B	A	L	F	D	Ø G	CH	Ø G1	Weight [g]
W0950322025	32	10	15	10.5	14	28	57	43	M10x1.25	15	17	19	78
W0950402025	40	12	17	12	16	32	66	50	M12x1.25	17.5	19	19	116
W0950502025	50	16	22	15	21	42	85	64	M16x1.5	22	22	22	226
W0950502025	63	16	22	15	21	42	85	64	M16x1.5	22	22	22	226

Note: Individually packed

**ARTICULATED JOINT - MODEL GA-K**

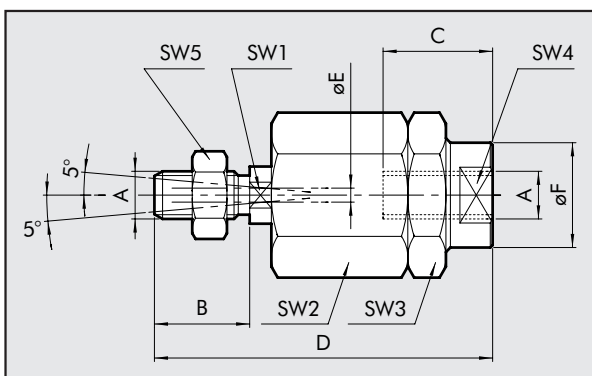

Code	Ø	A	B	C	D	ØF	ØE	SW <sub>1</sub>	SW <sub>2</sub>	SW <sub>3</sub>	SW <sub>4</sub>	SW <sub>5</sub>	Weight [g]
W0950322030	32	M10x1.25	20	20	71	22	4	12	30	30	19	17	216
W0950402030	40	M12x1.25	24	20	75	22	4	12	30	30	19	19	220
W0950502030	50	M16x1.5	32	32	103	32	4	20	41	41	30	24	620
W0950502030	63	M16x1.5	32	32	103	32	4	20	41	41	30	24	620

Note: Individually packed

**KIT FOR CYLINDER ASSEMBLY WITH SENSOR SLOTS**

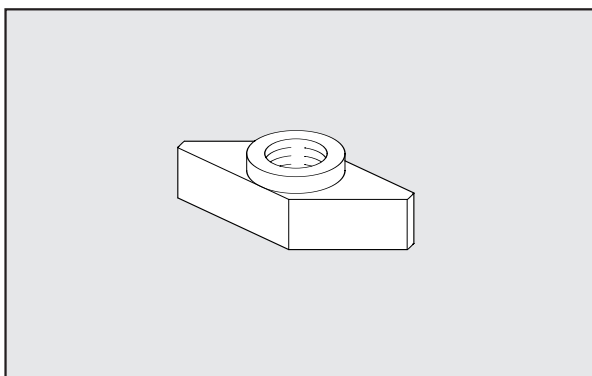

Code	Description	Weight [g]
0950003001	ACC. M4 T-SLOTTED FIXING PLATE	1
0950003002	ACC. M3 T-SLOTTED FIXING PLATE	1

Note: Individually packed

# CYLINDERS ISO 6431 STD AND TYPE "A" RETRACTABLE SENSOR TWO-FLAT: SPARES

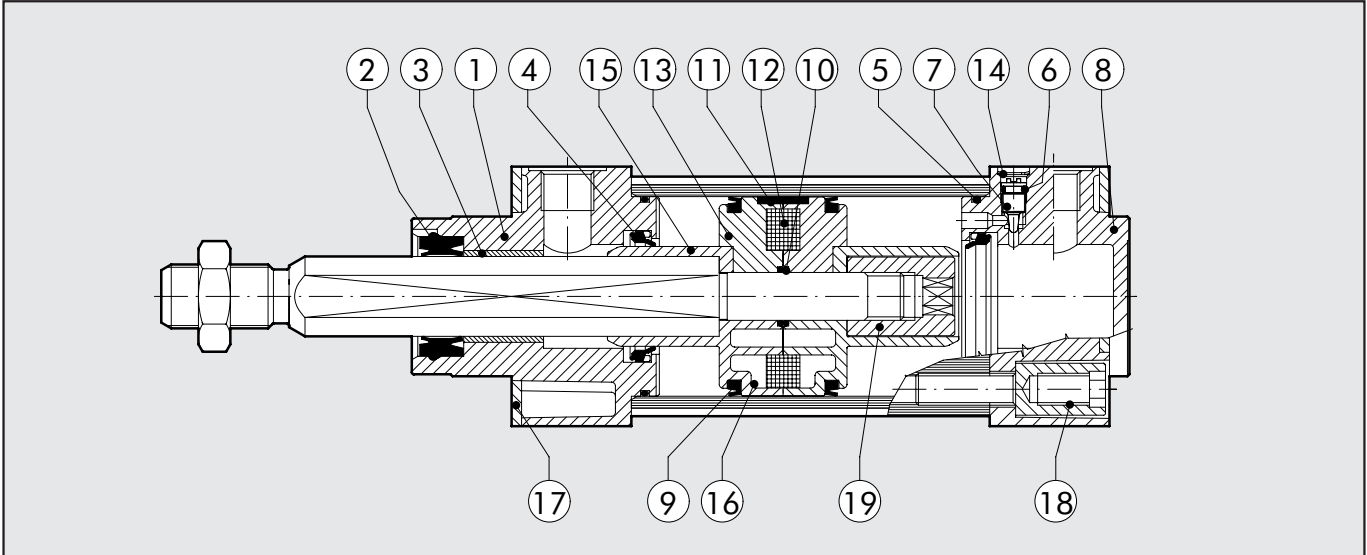

Type	Parts	Bore	Code
Complete set of polyurethane gaskets	2-4-5-6-9-10	Ø 32÷63	009 ... 0101F
Complete polyurethane front head kit	1-2-3-4-5-6-7-14-17-18	Ø 32÷63	009 ... 0110F
Complete polyurethane rear head kit	4-5-6-7-8-14-17-18	Ø 32÷63	009 ... 0111
Complete polyurethane piston kit	9-10-16-19	Ø 32÷63	009 ... 0604
Complete polyurethane head A+P+piston kit	1-2-3-4-5-6-7-8-9-10-14-16-17-18	Ø 32÷63	009 ... 0704F
Magnet	12	Ø 32÷63	009 ... 0800