

MACH 11 VALVES

The Mach 11 in-line valves with M7 threaded connection come in the following versions:

- 5/2 monostable and bistable
- 5/3 with closed, open or pressure centres.

Control:

- pneumatic
- solenoid/pneumatic 24 V

With an exceptional compact design only 11 mm wide, and excellent high performance, these valves can be used in numerous applications in industrial automation.

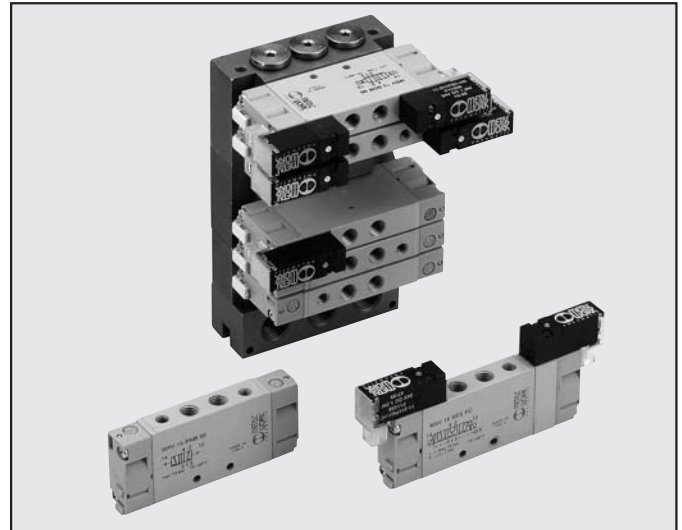

2

TECHNICAL DATA

Valve port thread	M7		
Pilot thread	M5		
Maximum external diameter of gaskets	mm	M5: Ø 11 mm M5: Ø 9 mm	
Operating temperature range	°C	-10 °C ÷ +60 °C	
Fluid	Filtered air without lubrication; lubrication, if used, must be continuous		
Screw for valve wall-mounting	M3		
Flow rate at 6 bar ΔP 1 bar	NI/min	400 NI/min	
Pressure range	bar	Electric	Pneumatic
		- monostable: 2 ÷ 7 bar - bistable: 1 ÷ 7 bar - 5/3: 2/7 bar	- pilot pressure: 2 ÷ 7 bar - valve: vacuum ÷ 10 bar - monostable control pressure values: 2 ÷ 10 bar - bistable control pressure values: 1 ÷ 10 bar - control pressure 5/3: 2 ÷ 10 bar - valve: vacuum ÷ 10 bar
Voltage range	24 VDC ±10%		
Power	1,2 W		
Insulation class	F155		
Degree of protection	IP 51*		
Solenoid rating	100% ED		
TRA/TRR monostable at 6 bar	ms	10 ms / 45 ms	4 ms / 9 ms
TRA/TRR bistable at 6 bar	ms	22 ms / 22 ms	4 ms / 4 ms
TRA/TRR 5/3 monostable at 6 bar	ms	22 ms / 22 ms	4 ms / 4 ms
*IP 65 on request			

COMPONENTS

- ① VALVE BODY: Aluminium
- ② CONTROL/END CAP: HOSTAFORM®
- ③ SPOOL: Aluminium
- ④ GASKETS: Polyurethane
- ⑤ PISTONS: HOSTAFORM®
- ⑥ PISTON GASKET: Polyurethane
- ⑦ FILTER: sintered bronze
- ⑧ PILOT: with integrated coil
- ⑨ SPRING: special steel
- ⑩ REMOVABLE IDENTIFICATION PLATE

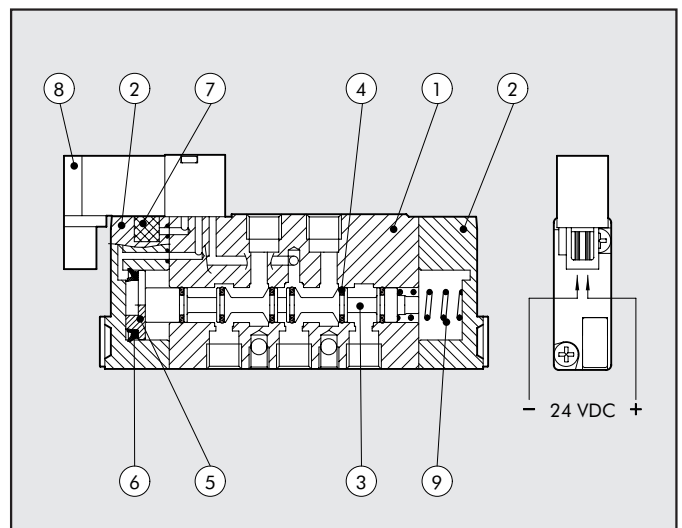

MACH 11 MODULARITY

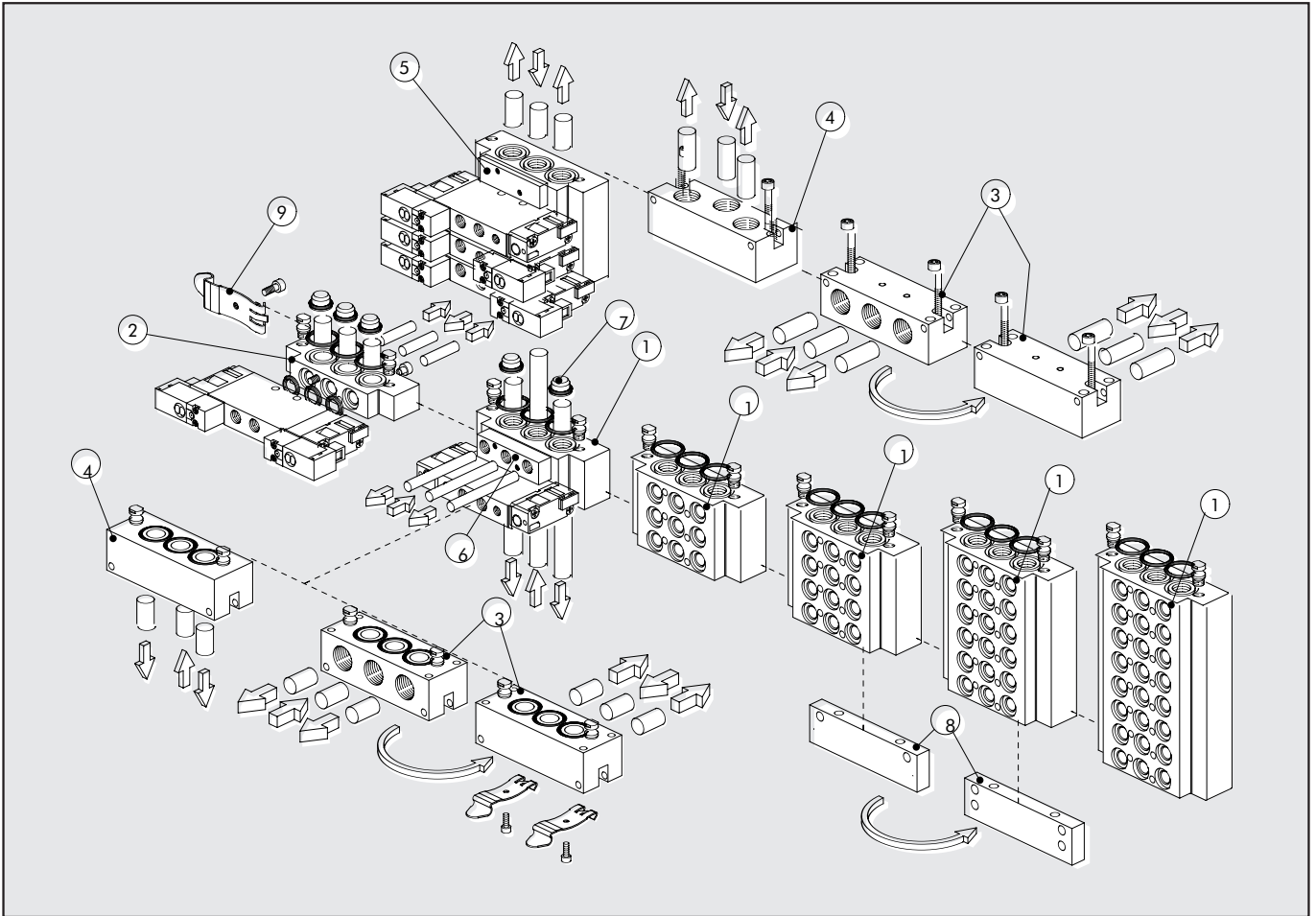

HOW TO FIX THE BASE

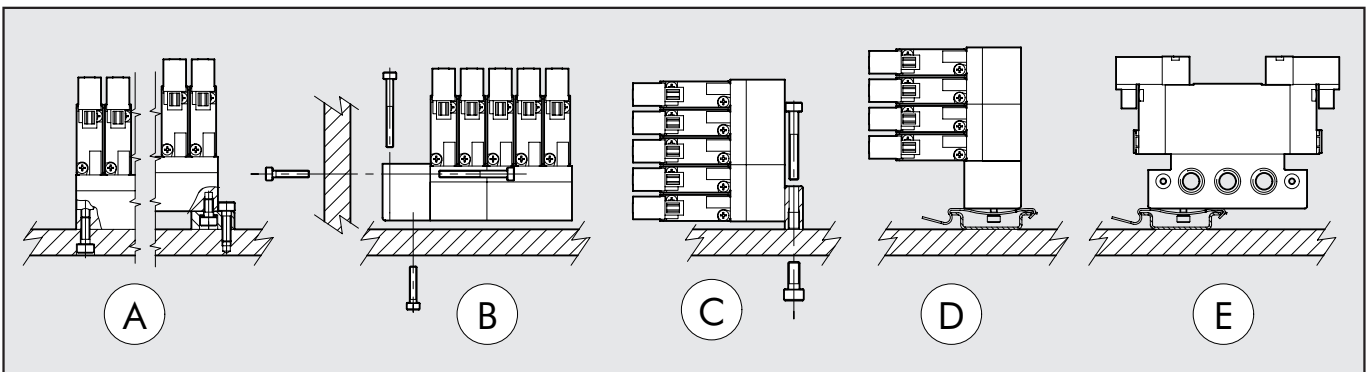

KEY TO CODES

M	S	V	1	5	S	O	B	0	0	2 4 V D C	
FAMILY		PORT		FUNCTION		OPERATORS 14		RESETTING		FURTHER DETAILS	
MSV	Mini-solenoid valve	1	M7	5	5/2	SO	Solenoid valve	B	bistable	00	5/2 standard
MPV	Mini pneumatic valve			6	5/3	SE	electric pilot-assisted pneumatic	S	mechanical spring	CC	closed centres
						PN				OC	open centres
										PC	pressure centres
											24VDC

Per versioni con comando elettrico IP65 contattare i nostri Uffici Commerciali.

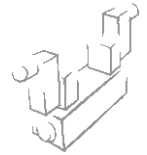

MACH 11 VALVES, PNEUMATIC

MONOSTABLE 5/2

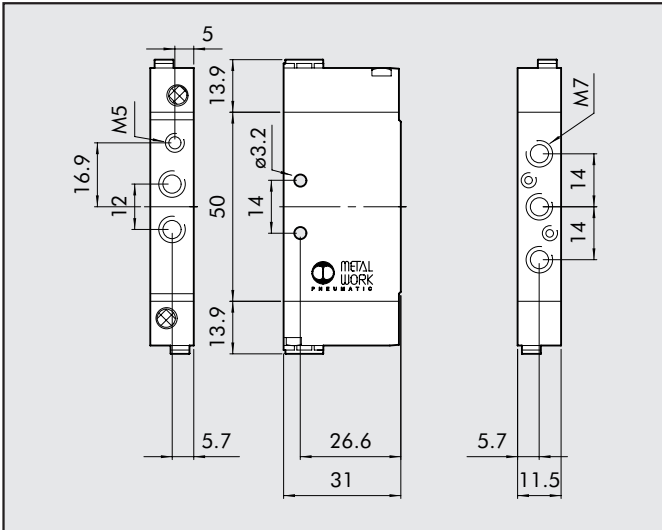

Symbol	Abbrev.	Code	Weight [g]
→ ←	MPV 15 PNS OO	7061010130	52

MONOSTABLE 5/3

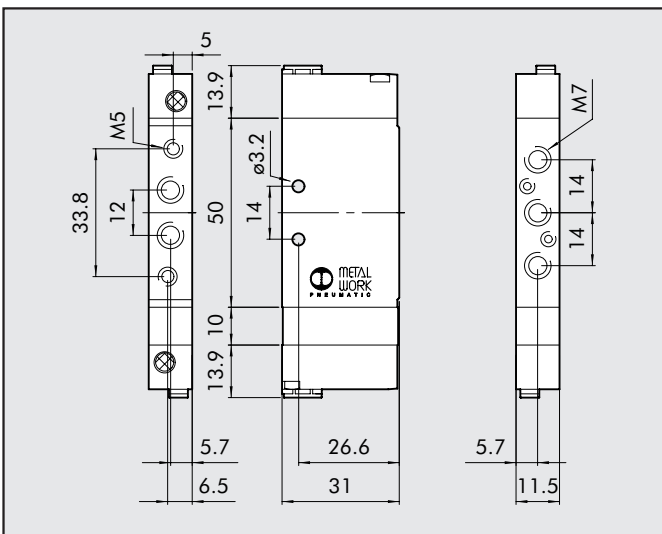

Symbol	Abbrev.	Code	Weight [g]
→ ←	MPV 16 PNS CC	7061010210	62
→ ←	MPV 16 PNS OC	7061010310	62
→ ←	MPV 16 PNS PC	7061010410	62

BISTABLE 5/2

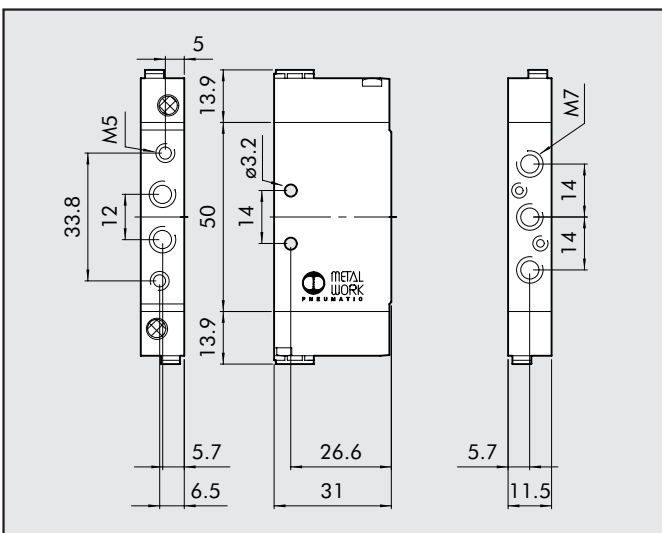



Symbol	Abbrev.	Code	Weight [g]
→ ←	MPV 15 PNB OO	7061010110	52

MACH 11 VALVES, SOLENOID-PNEUMATIC

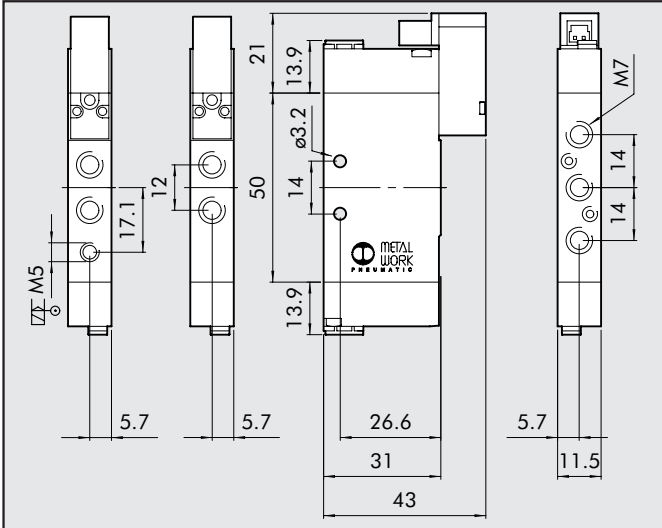





MONOSTABLE 5/2

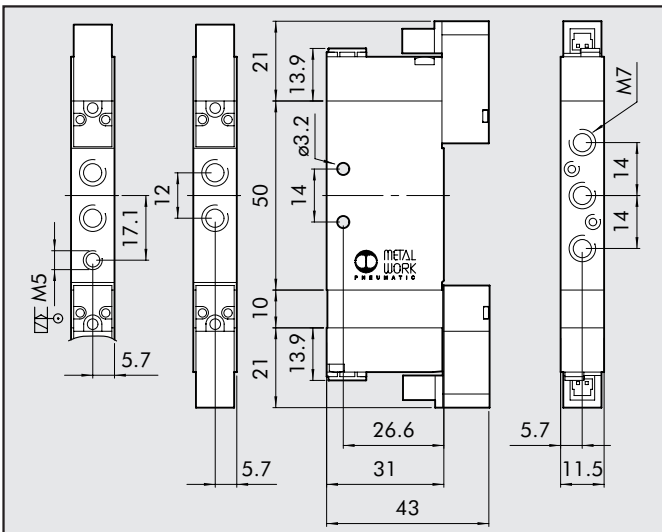

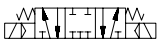
Symbol	Abbrev.	Code	Weight [g]
	MSV 15 SOS OO 24VDC	7061020132	60
	MSV 15 SES OO 24VDC	7061030132	60

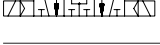
MONOSTABLE 5/3



Symbol	Abbrev.	Code	Weight [g]
	MSV 16 SOS CC 24VDC	7061020212	82
	MSV 16 SOS OC 24VDC	7061020312	82
	MSV 16 SOS PC 24VDC	7061020412	82
	MSV 16 SES CC 24VDC	7061030212	82
	MSV 16 SES OC 24VDC	7061030312	82
	MSV 16 SES PC 24VDC	7061030412	82

BISTABLE 5/2

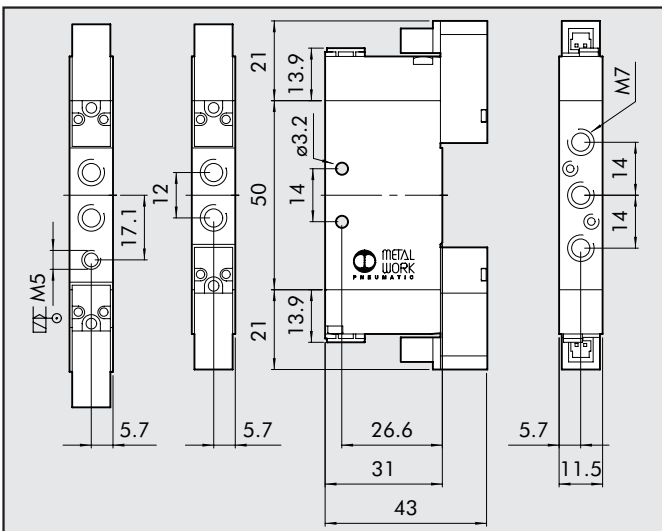

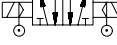
Symbol	Abbrev.	Code	Weight [g]
	MSV 15 SOB OO 24 VDC	7061020112	72
	MSV 15 SEB OO 24 VDC	7061030112	88

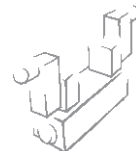

ACCESSORIES: MANIFOLD BASES FOR MACH 11 VALVES

MULTIPLE MANIFOLD BASE

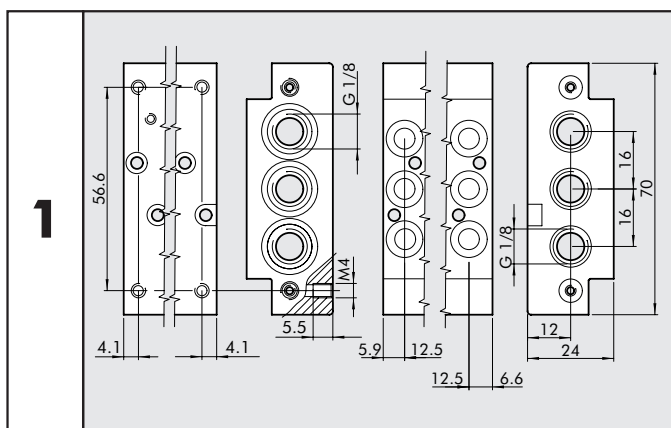

Code	Description	Weight [g]
0227400201	BASE, 2 POSN. FOR MACH 11	94
0227400301	BASE, 3 POSN. FOR MACH 11	140
0227400401	BASE, 4 POSN. FOR MACH 11	186
0227400601	BASE, 6 POSN. FOR MACH 11	282
0227400801	BASE, 8 POSN. FOR MACH 11	378

SEPARATE FEED MANIFOLD BASE

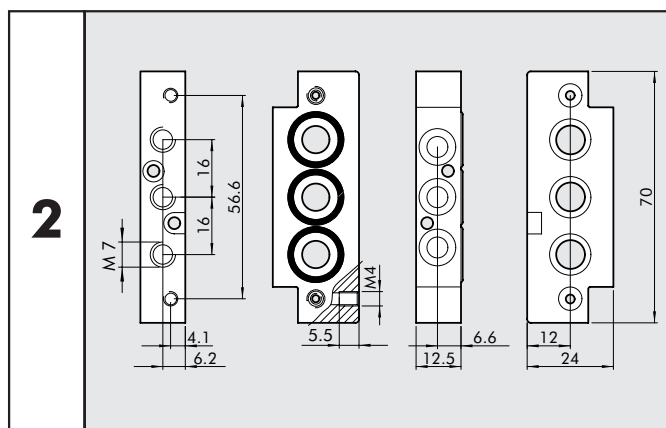

Code	Description	Weight [g]
0227400200	SEPARATE FEED MANIFOLD BASE FOR MACH 11	44

2

90° END PLATE

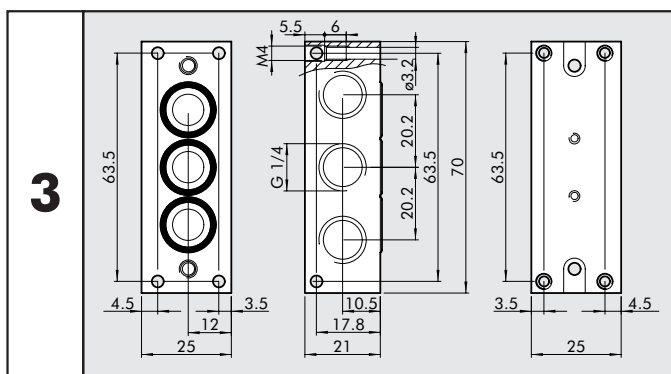

Code	Description	Weight [g]
0227400101	90° END PLATE 1/4 MACH 11	82

STRAIGHT END PLATE

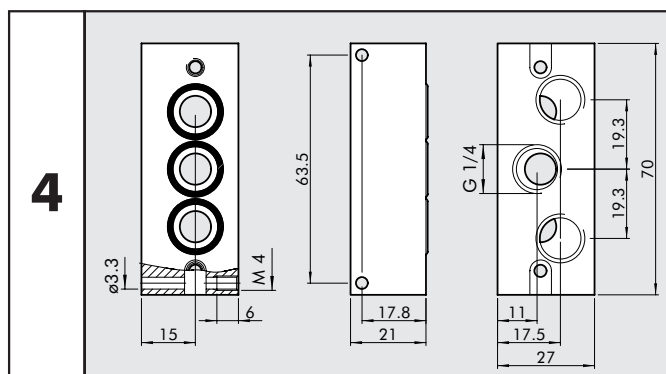

Code	Description	Weight [g]
0227400100	STRAIGHT END PLATE 1/4 FOR MACH 11	93

BLANKING PLATE

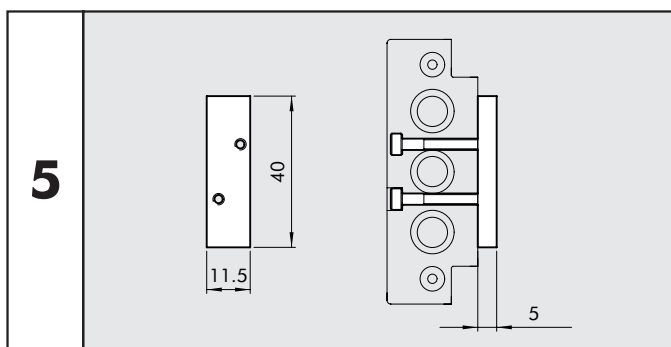

Code	Description	Weight [g]
0227400500	BLANKING PLATE FOR MACH 11	13

FEED BLOCK

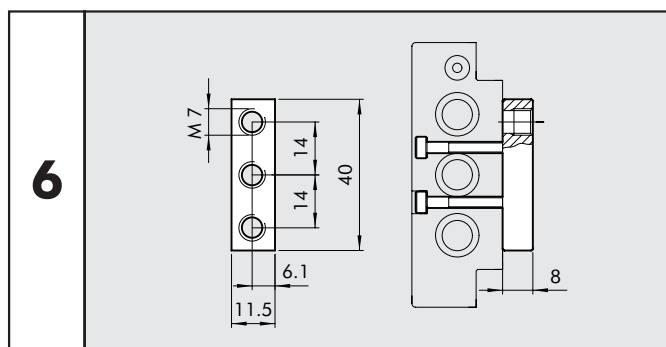

Code	Description	Weight [g]
0227400503	M7 FEED BLOCK FOR MACH 11	11

DIAPHRAGM

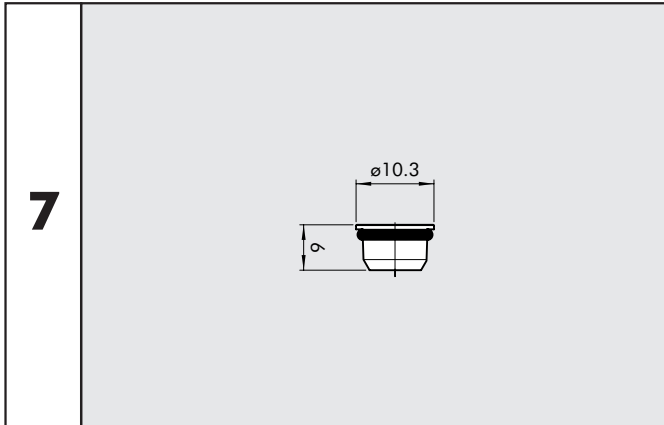

Code	Description	Weight [g]
022740000	DIAPHRAGM FOR MACH 11 BASES	3

BASE FIXING PLATE

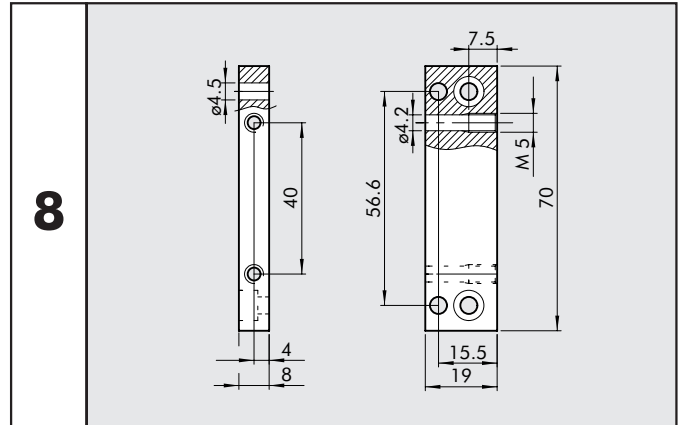

Code	Description	Weight [g]
022740054	FIXING PLATE FOR MACH 11 BASES	28

ACCESSORIES

PLUG-IN CONNECTOR

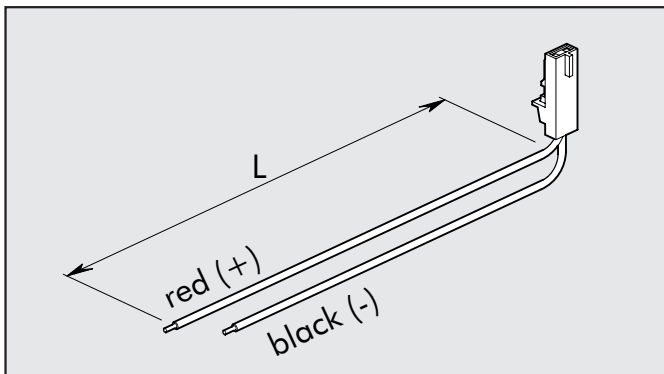

Code	Description
W0970512000	PLUG-IN CONNECTOR FOR MACH 11 L= 300

CONNECTION BRACKET ON DIN BAR

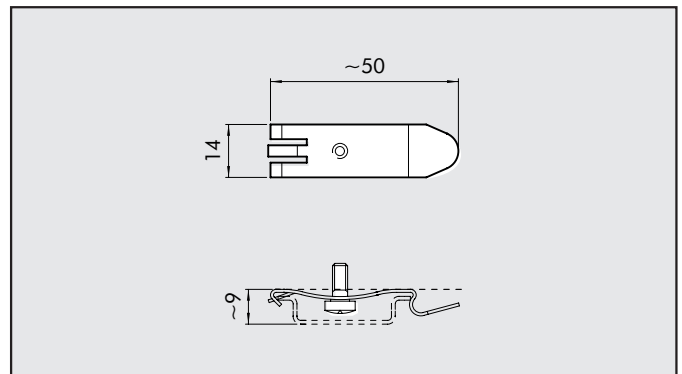

Code	Description
0227300600	CONNECTION BRACKET ON DIN BAR

SPARE PARTS

PLUG-IN PILOT FOR MACH 11

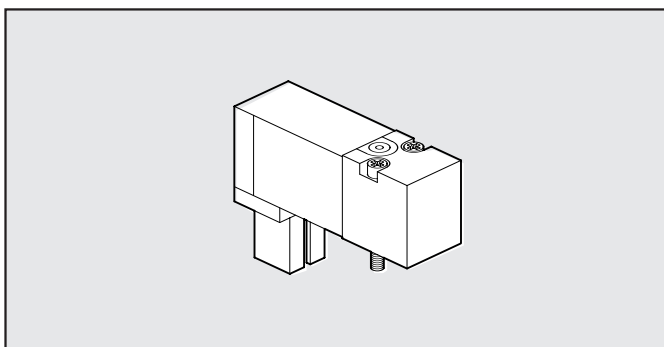

Codice	Descrizione
W4005001000	PILOTA PLUG-IN MACH 11 24VDC LED

NOTES

