

REDUCER WITH GAUGE FOR VALVES, SERIES "RMV"

The RMV-series miniature pressure regulator with pressure gauge for valves is specifically conceived for mounting on the outlets of valves with a 1/8" port.

With limited cross dimension, it can be fitted to a series of small valves. The body is 16.5 mm wide and fits exactly on the valves of the Mach 16 series for multiple electrical connection.

Using the RMV, it is possible to differentiate the pressure of each single output of the valves. For example, if you mount it on port 2 and not on port 4, the pressure can be reduced on port 2 only. If you mount one for each port, the pressure on port 2 will differ from that on port 4, which in turn is less than the feed pressure (outlet 1).

There are three 1/8" threaded RMV ports that are pneumatically connected in parallel. A small pressure gauge is mounted in one port; another port is plugged by an A7-type fitting and a third can take a fitting. The user, however, can decide whether the layout of components is to be modified or not. He might, for example, decide to mount three fittings to create a three-port reduced-pressure distributor.



TECHNICAL DATA

Threaded input connection	1/8" external thread
Threaded output connection	1/8" internal thread
Regulation range	bar 1 ÷ 8
	MPa 0.1 ÷ 0.8
	psi 14.5 ÷ 116
Input pressure	bar 2 ÷ 10
	MPa 0.2 ÷ 1
	psi 29 ÷ 145
Flow rate at 6.3 bar (0.63 Mpa - 91 psi) ΔP 1 bar	140 NI/1'
Flow rate at free exhaust at 6.3 bar (0.63 Mpa - 91 psi)	360 NI/1'
Fluid	filtered lubricated or unlubricated air
Maximum temperature at 10 Bar (1 Mpa - 145 psi)	-10°C ÷ +60° +14°F ÷ +140°F
Assembly position	on valves
Use instructions	The pressure must always be regulated in increasing values

ORDERING CODE

Code	Description
9061601	RMV 1/8"

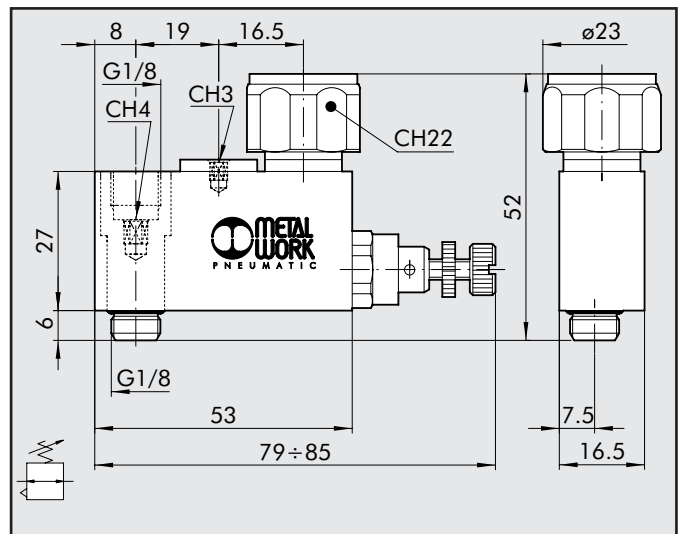

APPLICATIONS – ASSEMBLY

