

HDM + AS-INTERFACE HEAVY DUTY MULTIMACH

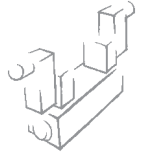

The HDM+AS-Interface system has been designed in such a way that the pneumatic input terminal contains all the electronics, signals and AS-I connectors. It is a very compact and sturdy system where everything is housed in a thick casing aluminium to protect the delicate components against impact. The valves and accessories are HDM standard, which means that you only need to replace the input terminal to convert the valve island with multiple connector into an AS-I island. All the advantages of the HDM system can be exploited: the possibility of mounting valves of different size, with fittings for pipes 4, 6 or 8; the insertion of intermediate modules with separate power supply or outlets; aluminium valves with chemical nickel plating enclosed in a protective casing in reinforced technopolymer, with an index of protection IP65. The arrangement of the functions continues the traditional optimisation of the HDMs: the user interface of the valves and bus all on one side, so that the fitter and service engineer have everything within easy reach: all compressed air connections on the other side; the connectors for AS-I cables on the opposite side longitudinally, so that several valve islands can be arranged in line, fixed on a DIN bar.

There are many AS-I terminal variants to meet all possible requirements:

- with 1 node, for controlling up to 4 valve solenoid pilots;
- with 2 nodes, for controlling up to 8 solenoid pilots;
- with 1 node for output and input for controlling up to 4 solenoid pilots and receiving up to 4 input signals. The input connectors are M8 or M12;
- with 2 nodes for output and input for controlling up to 8 solenoid pilots and receiving up to 8 input signals with M8 connectors;
- power supply with the AS-I yellow cable only;
- power supply with two cables: the yellow AS-I cable and the black power supply cable.
- traditional V.2.1 addressing or extended AB V.3.0 address for an increase in the node numbers which can be connected up to 62 and for a better diagnostics

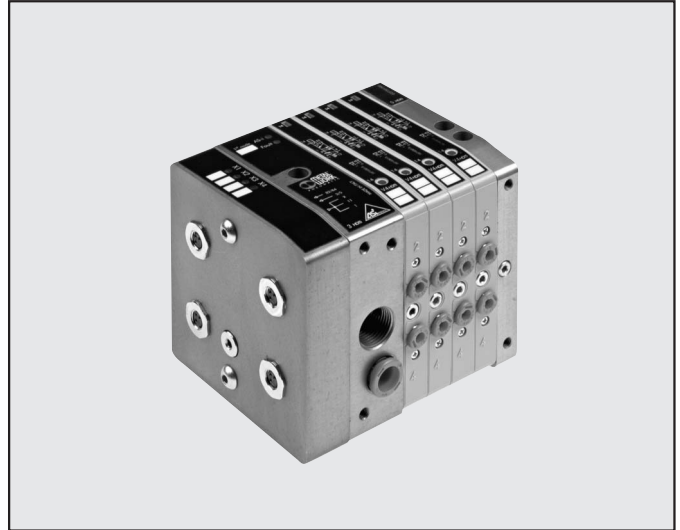

TECHNICAL DATA

Valve port connections	quick-connection ports 2 and 4, Ø 4,6,8 mm / power supply port for Ø 8 fitting / threaded exhaust port 3/8 or fitting Ø8 mm		
Connection on the end-plate for the supply of pilots	Automatic fitting Ø 4 mm		
Maximum number of pilots	terminal with 1 node = 4 / terminal with 2 node = 8		
Maximum number of valves	terminal with 2 node = 4 (same as the max. no. of pilots) / terminal with 2 node = 8 (same as the max. no. of pilots)		
Operating temperature range	°C -10 ÷ +60		
Fluid	Filtered air without lubrication; lubrication, if used, must be continuous		
Flow rate at 6 bar ΔP 1bar	11mm Ø 4 = 200	11mm Ø 6 = 500	14mm Ø 8 = 800
Pressure range	X (pilot supply) 2 ÷ 7 bar		1-11 (valve supply) vacuum at 10 bar
		2 ÷ 7 bar	
Voltage range	24 VDC ±10%		
Power for each pilot	W 0,6		
Solenoid Pilot Insulation class	F155		
Degree of protection	IP65 with common outlets		
Solenoid rating	100% ED		
TRA/TRR 2X3/2 monostable at 6 bar	ms 8 / 45		
TRA/TRR 5/2 monostable at 6 bar	ms 8 / 33		
TRA/TRR 5/2 bistable at 6 bar	ms 20 / 20		
TRA/TRR 5/3 cc monostable at 6 bar	ms 20 / 20		
Note on use	Insert the pipes in the fittings, before passing air through the valves, otherwise the basket may be pulled out of its seat by the flow of air.		

COMPONENTS

- ① Exhaust – Solenoid pilot 82/84
- ② Valve supply – port 1
- ③ Threaded connection of exhausts 3/5
- ④ Valve supply – port 11
- ⑤ Electrical control supply X
- ⑥ Blind end-plate
- ⑦ Screw for valve wall-mounting
- ⑧ Utility port for pipe Ø 8 mm
- ⑨ Utility port for pipe Ø 6 mm
- ⑩ Utility port for pipe Ø 4 mm
- ⑪ Manual control
- ⑫ LED (LED on, solenoid valve energised)
- ⑬ Pneumatic symbol
- ⑭ Identification of the monostable or bistable manual control
- ⑮ Valve ordering code
- ⑯ Valve identification code
- ⑰ Blank space for valve number
- ⑱ Black cable for 24V (if present)
- ⑲ AS-INTERFACE yellow cable
- ⑳ AS-INTERFACE led

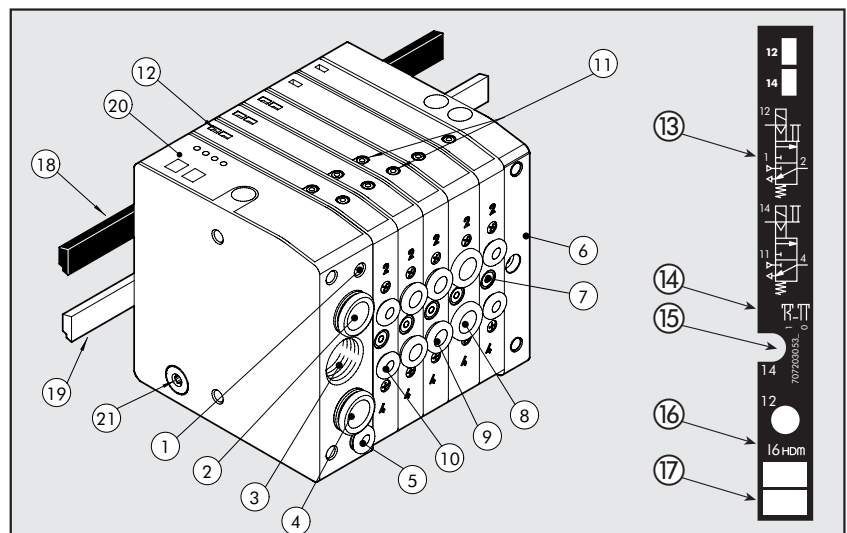

THE MULTIMACH WORLD: FLEXIBILITY

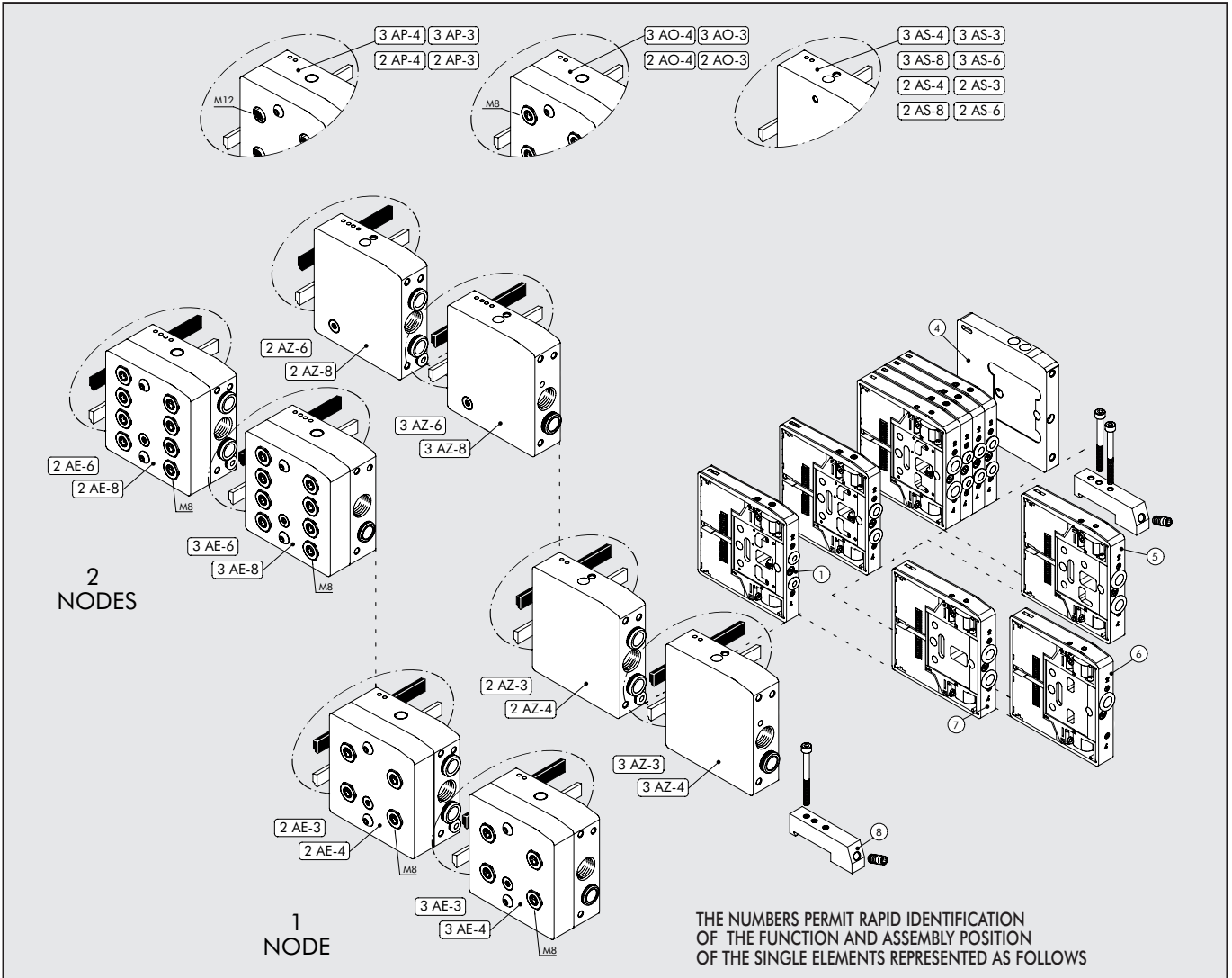

FIXING THE BASE

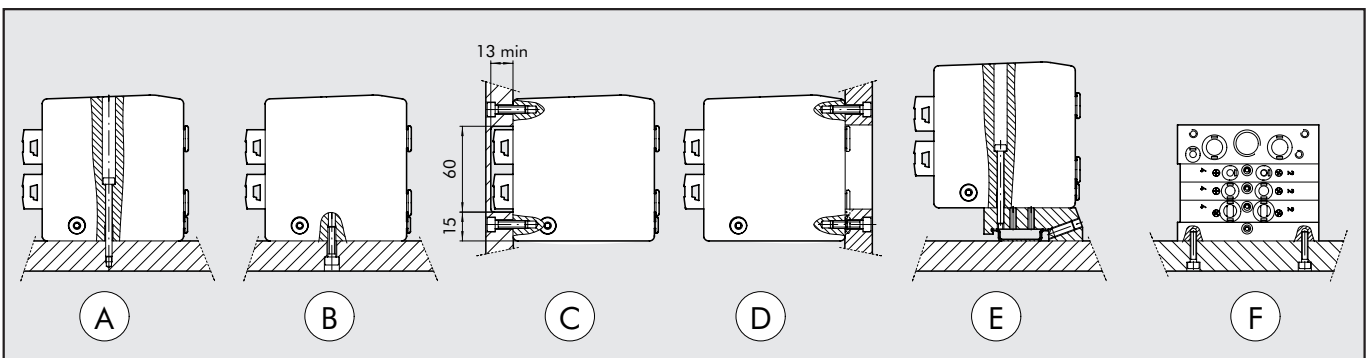

- A:** Fixing from above using the 1 or 1-1 input terminal and the blind terminal.
B-C: Fixing from above using the 1 or 1-1 input terminal and the blind terminal, using the M5 threads on the bottom and the rear of the terminals.
D: Fixing from above using the 1 or 1-1 input terminal and the blind terminal, using the M5 threads on the front of the terminals. An opening for the pipes is made in the plate.
E: Fixing on the DIN bar with end-plate 1 or 1-11 and blind and plate, using the push-in bracket code 0227301600.
F: Lateral fixing using the blind terminal, and its the M4 threads on the side lateral.
Note: The sole fixing admitted is the one showed.

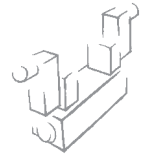

KEY TO CODE - MULTIMACH-UNIT HDM - AS-INTERFACE

H	D	M	2	AS-4	M	16-W8-W6-O4-L8-5	16
VALVE	INPUT END-PLATE	SUPP. ELETT	MANUAL TYPE	TYPE OF VALVE	FURTHER DETAILS		
Heavy duty Multimach IP65	2 End-plate 1-11 3 End-plate 1	Version with standard address ** AS-4 1 node, 4 OUT, yellow cable AS-8 2 nodes, 8 OUT, yellow cable ** AO-4 1 node, 4OUT and 4 IN, M8, yellow cable ** AP-4 1 node, 4OUT and 4 IN, M12, yellow cable ** AZ-4 1 node, 4OUT, yellow cable and black cable AZ-8 2 nodes, 8 OUT, yellow cable and black cable ** AE-4 1 node, 4 OUT and 4 IN, M8, yellow cable and black cable AE-8 2 nodes, 8 OUT and 8 in M8, yellow cable and black cable Version with extended address AS-3 1 node, 4 OUT, yellow cable AS-6 2 nodes, 8 OUT, yellow cable AO-3 1 node, 4 OUT and 4 IN, M8, yellow cable AP-3 1 node, 4 OUT and 4 IN, M12, yellow cable AZ-3 1 node, 4 OUT, yellow cable and black cable AZ-6 2 nodes, 8 OUT, yellow cable and black cable AE-3 1 node, 4 OUT and 4 IN, M8, yellow cable and black cable AE-6 2 nodes, 8 OUT and 8 in M8, yellow cable and black cable	M Monostable manual control B Bistable manual control	I n° 2 3/2 NC W n° 2 3/2 NO L 3/2 NO + 3/2 NC V 5/2 monostable K 5/2 bistable O 5/3 monostable *F 5/2 monostable 5 blind end-plate 6 Passing-intermed. 7 Blind intermediate 20 exhaust section. 4 cartridge 4 6 cartridge 6 8 cartridge 8	16 n° 2 brackets for DIN bar		

* uses a single PIN (like the V) and occupies 2 signals ** standard versions handled from stock

MANUAL CONTROLS

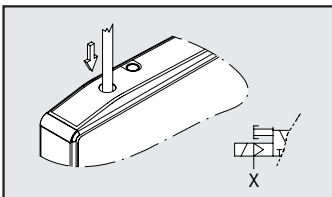

MONOSTABLE OVERRIDE PORT 2
with direct actuation on the spool

- Press and hold the manual control in position (not necessary for bistable type K valve)
- Release the manual control:
 - With valves type I, W, L, V and F, the manual control returns to the home position, and the valve repositions.
 - With type K valves, the manual control remains in position and the valve remains switched.
 - With type O valves, the manual control does not return completely to the home position but the valve does reposition.

N.B.: The pilot power supply X need not be present.

- The reference code for the monostable control ends in 0 (2 for type F).

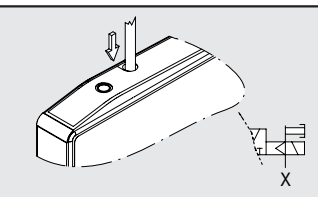
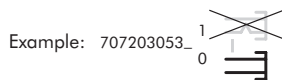

MONOSTABLE OVERRIDE PORT 4
servo-assisted

- Press and hold the manual control in position (not necessary for bistable type K valve)
- Release the manual control:
 - The manual control returns to the home position.
 - Valves type I, W, L, V and F reposition.
 - The type K valve remains switched

With type F and V valves, this manual control is not present.

N.B.: The pilot power supply X must be present.

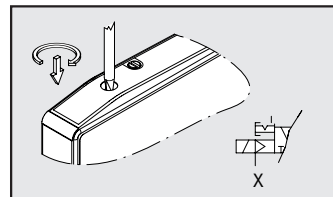

BISTABLE OVERRIDE PORT 2
with direct actuation on the spool

- Press the manual control right in then turn it fully clockwise and Leave it in position.
- Rotate the manual control fully anticlockwise, and then release it.
 - With valves type I, W, L, V and F, the manual control returns to the home position, and the valve repositions.
 - With type K valves, the manual control remains in position and the valve remains switched.
 - With type O valves, the manual control does not return completely to the home position but the valve does reposition.

N.B.: The pilot power supply X need not be present.

- The reference code for the monostable control ends in 1 (3 for type F).

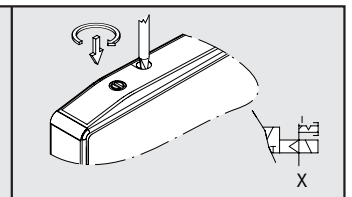
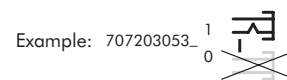

BISTABLE OVERRIDE PORT 4
servo-assisted

- Press the manual control right in then turn it fully clockwise and Leave it in position.
- Rotate the manual control fully anticlockwise, and then release it:
 - The manual control returns to the home position.
 - Valves type I, W, L and O reposition.
 - The type K valve remains switched

With type F and V valves, this manual control is not present.

N.B.: The pilot power supply X must be present.

WIRING DIAGRAM

NOTE: The type f monostable valve uses one PIN only (like the V) but occupies 2 signals.

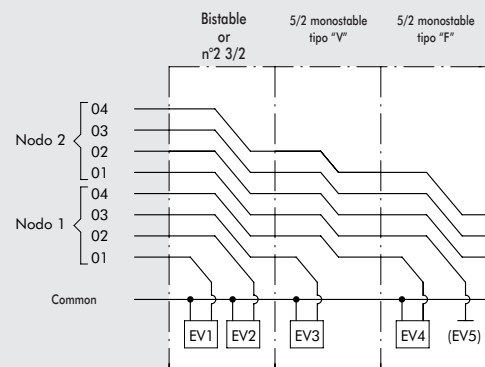
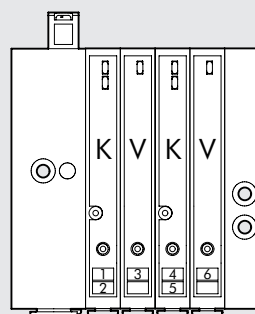
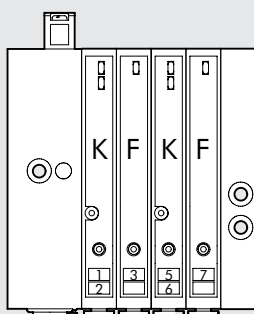

VALVE DIMENSIONS HDM Ø 4

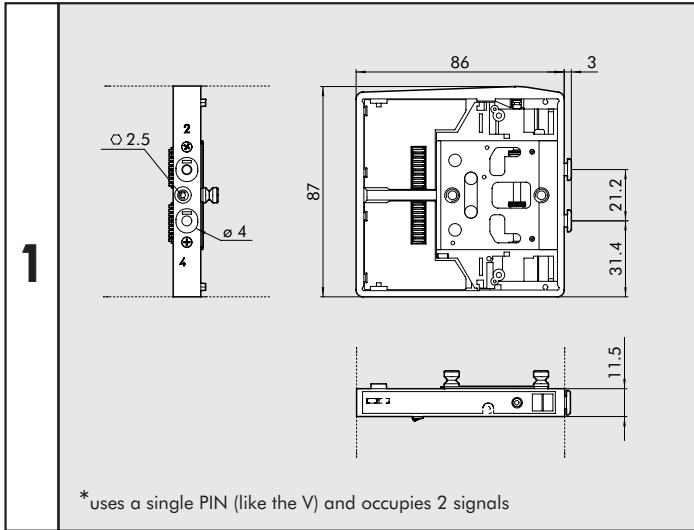

Symbol	Manual Control	Code	Weight [g]
I4 _{HDM}	monostable	7071030530	130
	bistable	7071030531	
W4 _{HDM}	monostable	7071030630	130
	bistable	7071030631	
L4 _{HDM}	monostable	7071030730	130
	bistable	7071030731	
V4 _{HDM}	monostable	7071030130	115
	bistable	7071030131	
*F4 _{HDM}	monostable	7071030132	115
	bistable	7071030133	
K4 _{HDM}	monostable	7071030110	130
	bistable	7071030111	
O4 _{HDM}	monostable	7071030210	130
	bistable	7071030211	

VALVE DIMENSIONS HDM Ø 6

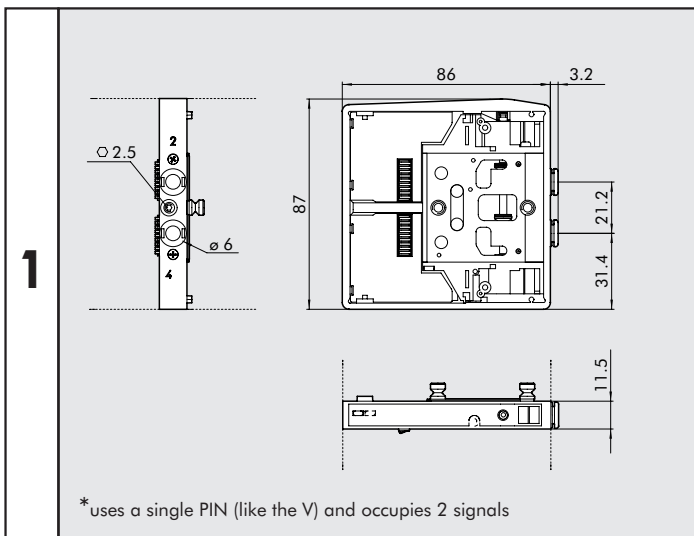

Symbol	Manual Control	Code	Weight [g]
I6 _{HDM}	monostable	7072030530	130
	bistable	7072030531	
W6 _{HDM}	monostable	7072030630	130
	bistable	7072030631	
L6 _{HDM}	monostable	7072030730	130
	bistable	7072030731	
V6 _{HDM}	monostable	7072030130	115
	bistable	7072030131	
*F6 _{HDM}	monostable	7072030132	115
	bistable	7072030133	
K6 _{HDM}	monostable	7072030110	130
	bistable	7072030111	
O6 _{HDM}	monostable	7072030210	130
	bistable	7072030211	

VALVE DIMENSIONS HDM Ø 8

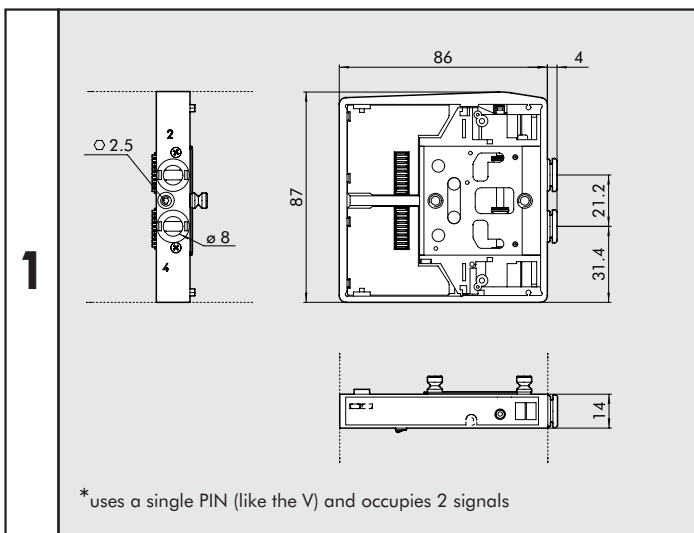

Symbol	Manual Control	Code	Weight [g]
I8 _{HDM}	monostable	7073030530	140
	bistable	7073030531	
W8 _{HDM}	monostable	7073030630	140
	bistable	7073030631	
L8 _{HDM}	monostable	7073030730	140
	bistable	7073030731	
V8 _{HDM}	monostable	7073030130	130
	bistable	7073030131	
*F8 _{HDM}	monostable	7073030132	130
	bistable	7073030133	
K8 _{HDM}	monostable	7073030110	140
	bistable	7073030111	
O8 _{HDM}	monostable	7073030210	140
	bistable	7073030211	

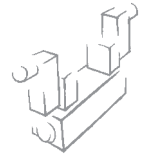

ACCESSORIES

TERMINAL 1-11 AS-4, AS-8, AS-3, AS-6

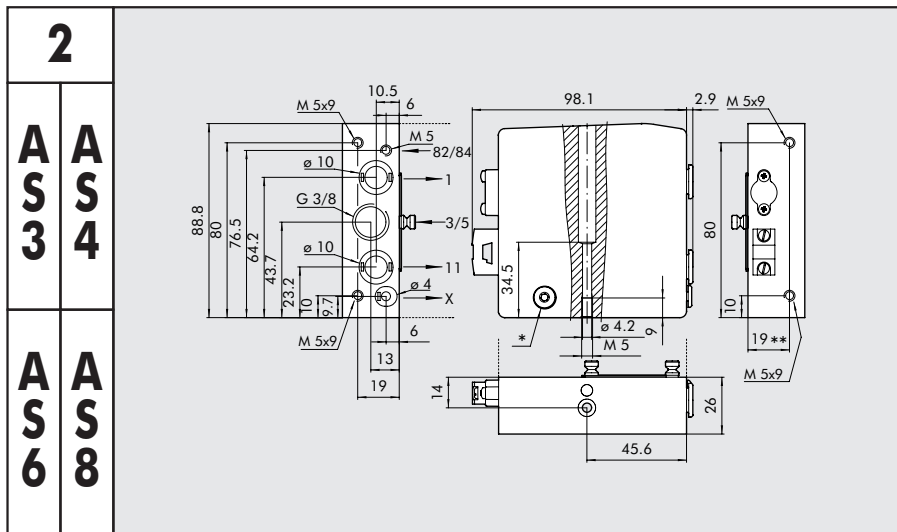

Code	Description
0227301203	KIT TERMINAL HDM 1-11 AS-4 1 node, 4 Out, yellow cable
0227301209	KIT TERMINAL HDM 1-11 AS-8 2 nodes, 8 Out, yellow cable
0227301230	KIT TERMINAL HDM 1-11 AS-3 1 node extended address, V3.0 4 Out, yellow cable
0227301231	KIT TERMINAL HDM 1-11 AS-6 2 nodes extended address, V3.0 8 Out, yellow cable

* M7 plug for 2nd node addressing.
N.B. For versions with 2 nodes only

** 21 for AS-8

TERMINAL 1 AS-4, AS-8, AS-3, AS-6

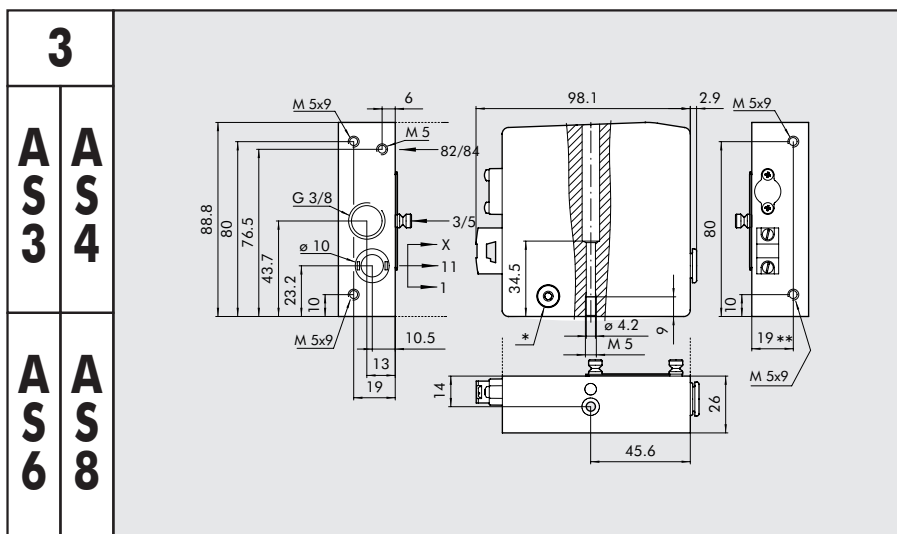

Code	Description
0227301202 •	KIT TERMINAL HDM 1 AS-4 1 node, 4 Out, yellow cable
0227301208	KIT TERMINAL HDM 1 AS-8 2 nodes, 8 Out, yellow cable
0227301232	KIT TERMINAL HDM 1 AS-3 1 node extended address, V3.0 4 Out, yellow cable
0227301233	KIT TERMINAL HDM 1 AS-6 2 nodes extended address, V3.0 8 Out, yellow cable

* M7 plug for 2nd node addressing.
N.B. For versions with 2 nodes only

** 21 for AS-8

• standard versions handled from stock

TERMINAL 1-11 AO-4, AO-3 M8

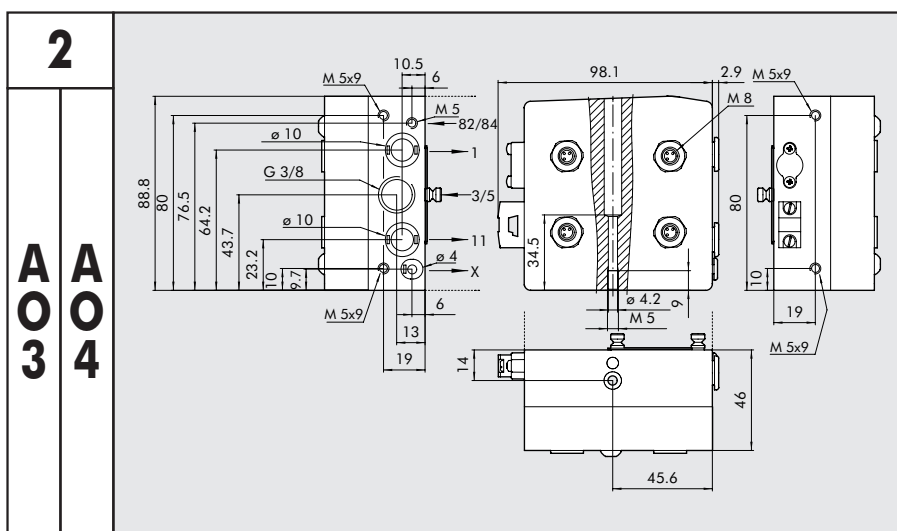

Code	Description
0227301219	KIT TERMINAL HDM 1-11 AO-4 1 node, 4 Out and 4 In M8, yellow cable
0227301234	KIT TERMINAL HDM 1-11 AO-3 1 node extended address, V3.0 4 Out and 4 In M8, yellow cable

TERMINAL 1 AO-4, AO-3 M8

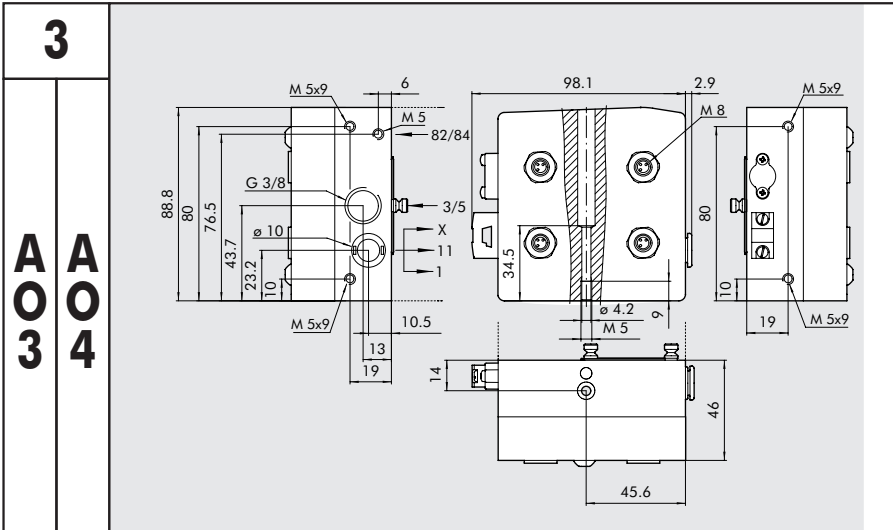

Code	Description
0227301218 •	KIT TERMINAL HDM 1 AO-4 1 node, 4 Out and 4 In M8, yellow cable
0227301235	KIT TERMINAL HDM 1 AO-3 1 node extended address, V3.0 4 Out and 4 In M8, yellow cable

• standard versions handled from stock

TERMINAL 1-11 AP-4, AP-3 M12

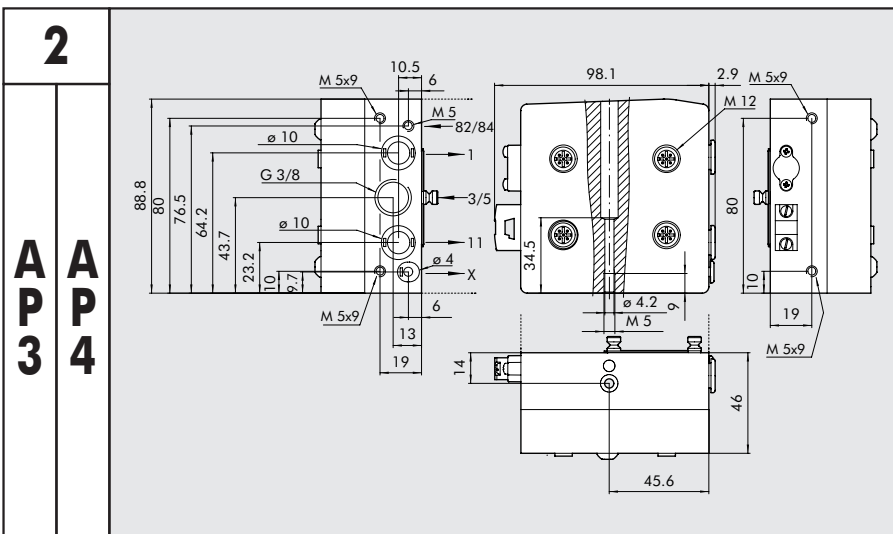

Code	Description
0227301213	KIT TERMINAL HDM 1-11 AP-4 1 node, 4 Out and 4 In M12, yellow cable
0227301236	KIT TERMINAL HDM 1 AP-3 1 node extended address, V3.0 4 Out and 4 In M12, yellow cable

TERMINAL 1 AP-4, AP-3 M12

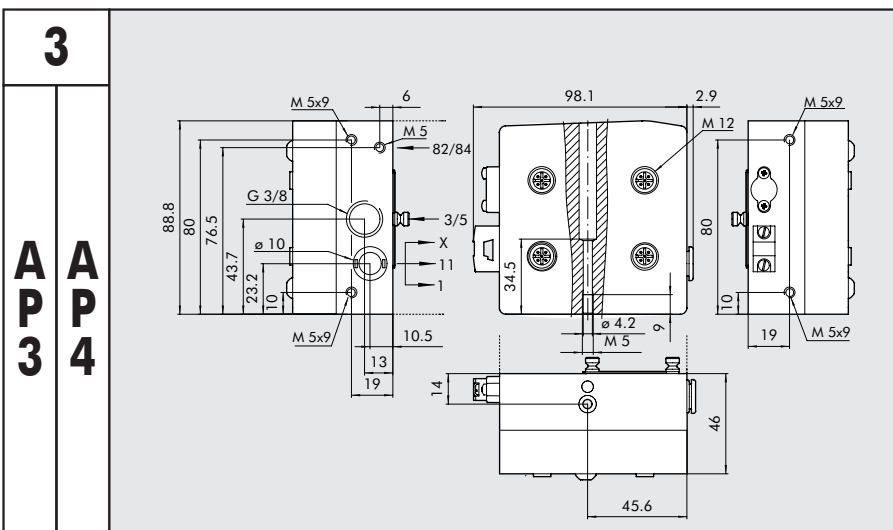

Code	Description
0227301212 •	KIT TERMINAL HDM 1 AP-4 1 node, 4 Out and 4 In M12, yellow cable
0227301237	KIT TERMINALE HDM 1 AP-3 1 node extended address, V3.0 4 Out and 4 In M12, yellow cable

• standard versions handled from stock

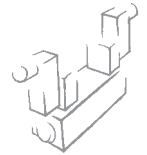

TERMINAL 1-11 AE-4, AE-3 M8

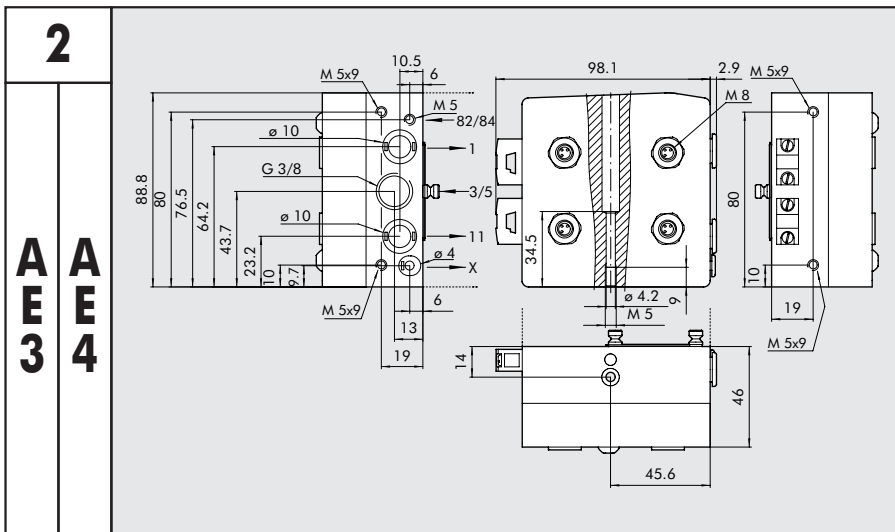

Code	Description
0227301215	KIT TERMINAL HDM 1-11 AE-4 1 node, 4 Out and 4 In M8, yellow cable and black cable
0227301238	KIT TERMINAL HDM 1-11 AE-3 1 node extended address, V3.0 4 Out and 3 In M8, yellow cable and black cable

TERMINAL 1 AE-4, AE-3 M8

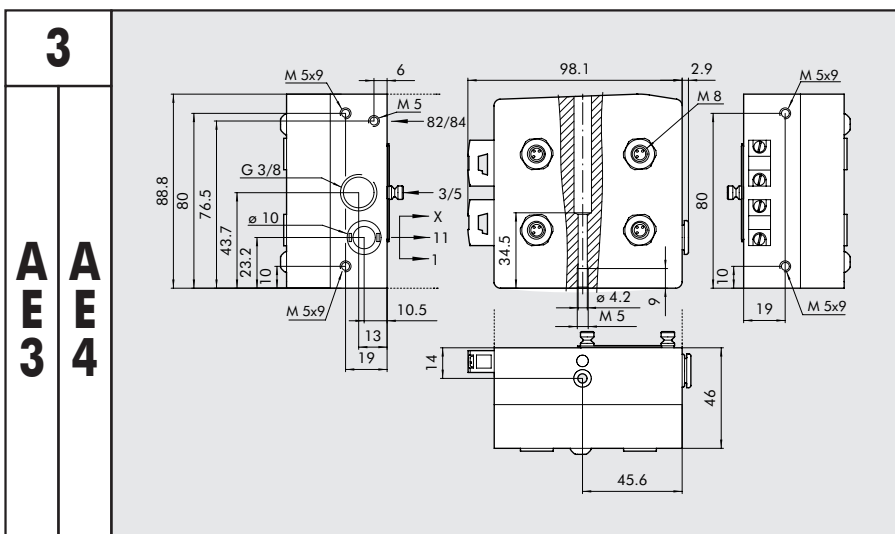

Code	Description
0227301214	• KIT TERMINAL HDM 1 AE-4 1 node, 4 Out and 4 In M8, yellow cable and black cable
0227301239	KIT TERMINAL HDM 1 AE-3 1 node extended address, V3.0 4 Out and 3 In M8, yellow cable and black cable

• standard versions handled from stock

TERMINAL 1-11 AE-8, AE-6 M8

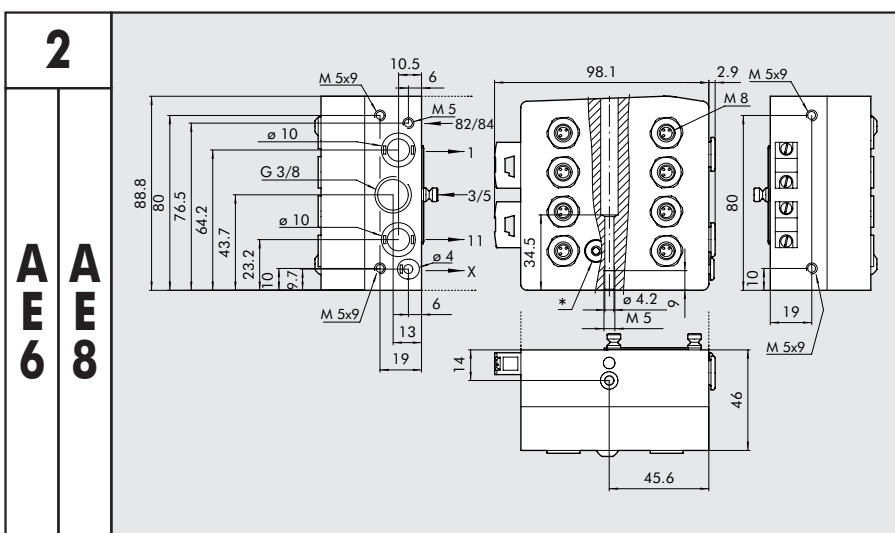

Code	Description
0227301217	KIT TERMINAL HDM 1-11 AE-8 2 nodes, 8 Out and 8 In M8, yellow cable and black cable
0227301240	KIT TERMINAL HDM 1-11 AE-6 2 nodes extended address, V3.0 8 Out and 8 In M8, yellow cable and black cable

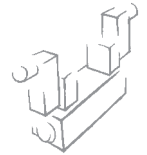

BLIND END-PLATE

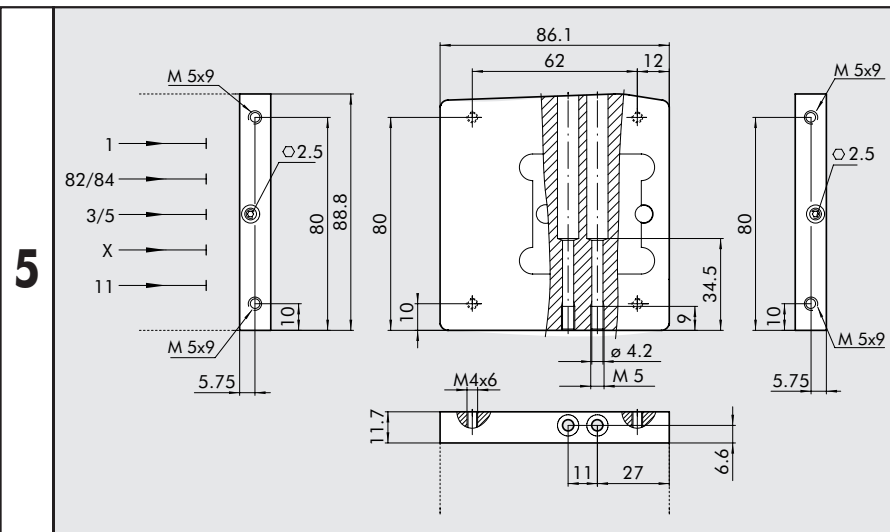

Code	Description	Weight [g]
0227301500	BLIND END-PLATE HDM	230

INTERMEDIATE THROUGH

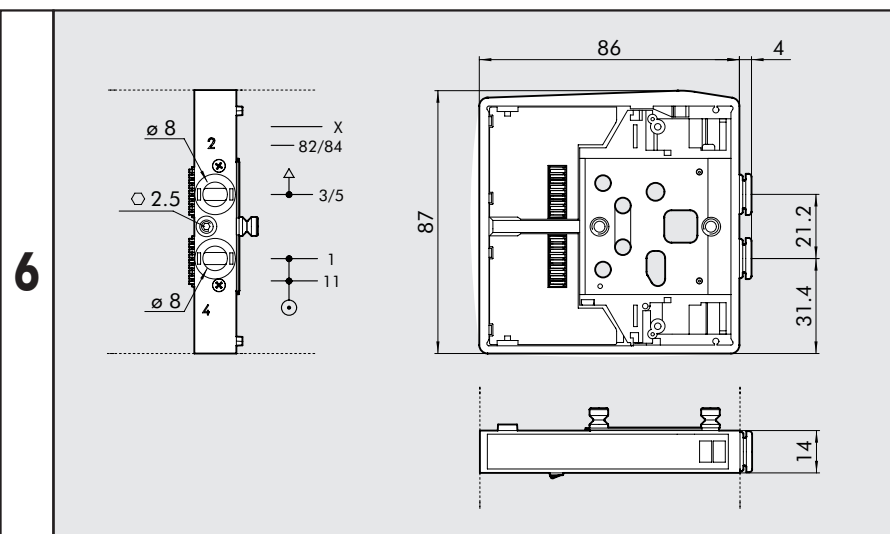

Code	Description	Weight [g]
0227301301	INTERMEDIATE THROUGH HDM	120

INTERMEDIATE BLIND

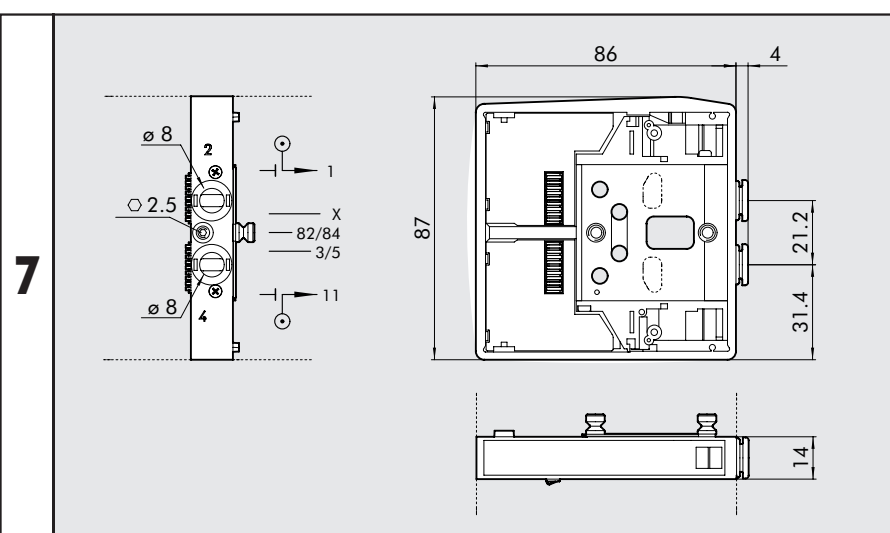

Code	Description	Weight [g]
0227301302	INTERMEDIATE BLIND HDM	117

INTERMEDIATE EXHAUST SWITCH

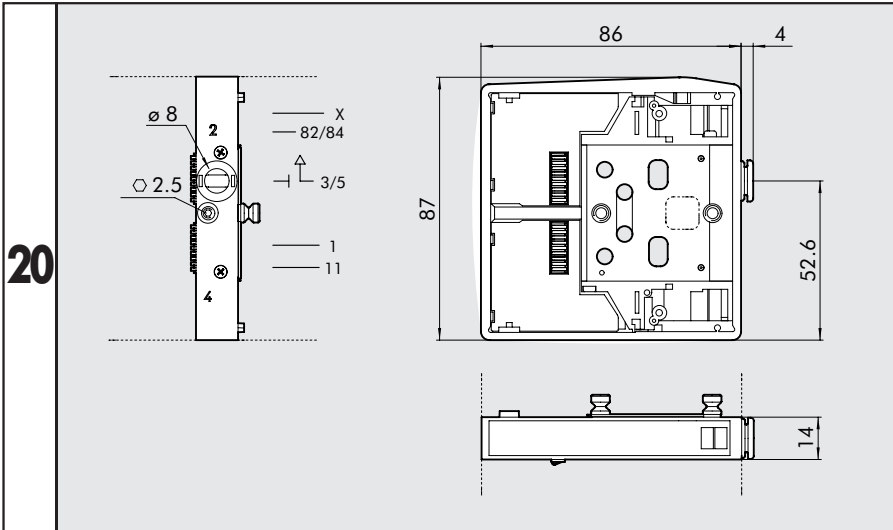

Code	Description	Weight [g]
0227301303	INTERMEDIATE EXHAUST SWITCH HDM	125

CONNECTION BRACKETS ON DIN BAR

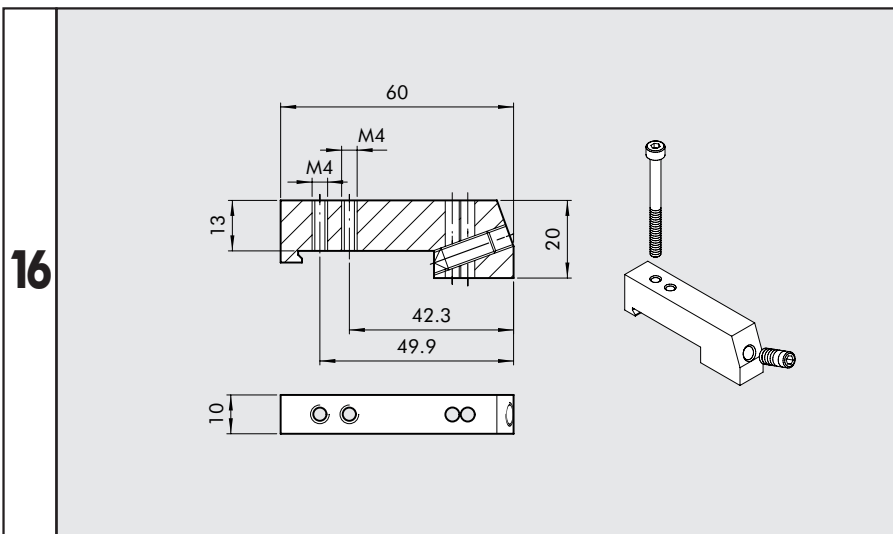

Code	Description	Weight [g]
0227301600	CONNECTION BRACKETS ON DIN BAR HDM/CM	30

Supplied complete with one M4x45 screws and one M6 grub screw Individually packed

SILENCER FOR FITTING, Ø 8

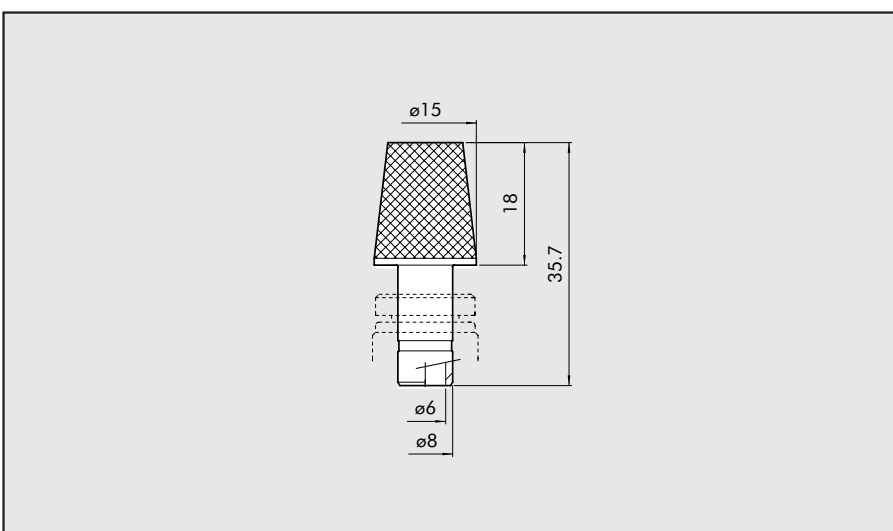

Code	Description	Weight [g]
W0970530084	SILENCER FOR FITTING, Ø 8	15

At the 3/5-exhaust port of the intermediate through reference 6 and of the exhaust switch reference 20

