

Since they were first developed, rodless cylinders have undergone continuous changes to make them more reliable, perform better and last longer.

As you will see on the following pages, there have been three successive versions called, for the purpose of easy identification, "OLD RELEASE", "INTERMEDIATE RELEASE" and "LAST RELEASE". Some spare parts are fully interchangeable for all the versions available, whereas others unfortunately are not.

This is the reason why the indications given on the following pages must be followed carefully.

In practice, the first thing to do is to identify the following elements:

- **What version is my cylinder? Is it an OLD, an INTERMEDIATE or a LAST?**
To help you in identifying it, refer to the indications given on the following pages.
- **What type is my cylinder ?**
The cylinder is identified by the first three digits of the code.
Another vital piece of information is clearly the bore.

Now we have all the data required to start the consultation and help us to choose exactly what we need for servicing our cylinders, by knowing that:

If the cylinder is an OLD RELEASE and it's necessary to replace some spare parts of it - either if it concerns pistons or guiding plate or simply gaskets - you must calculate for replacing all the correlated parts, and more precisely: for example, if a cylinder has a diameter 16 and you want to replace its piston, you will have to order the piston kit, as well as the kit for the right and left heads and also the carriage kit and the correspondent band support kit.

For the other diameters can be applied what written above, except for the heads which needn't to be replaced.

The only spare part which remains unchanged is the band kit.

If the cylinder is an INTERMEDIATE RELEASE and you must replace its piston you have to calculate for replacing also the carriage kit specifying the cylinder type and viceversa (N.B. for the diameter 16 you have to replace also the right and left heads).

Unchanged are the band, gasket and band support kits.

If the cylinder is a LAST RELEASE there is no problem: you order and replace the spare parts that you need by consulting the attached documentation which indicates the codes of the spare parts.

All the details concerning the codes are contained in the attached documentation.

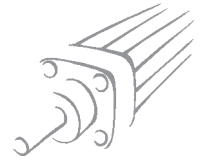

The cylinder is a **LAST RELEASE** (or it is a $\varnothing 63$) if the end of the carriage looks like this:

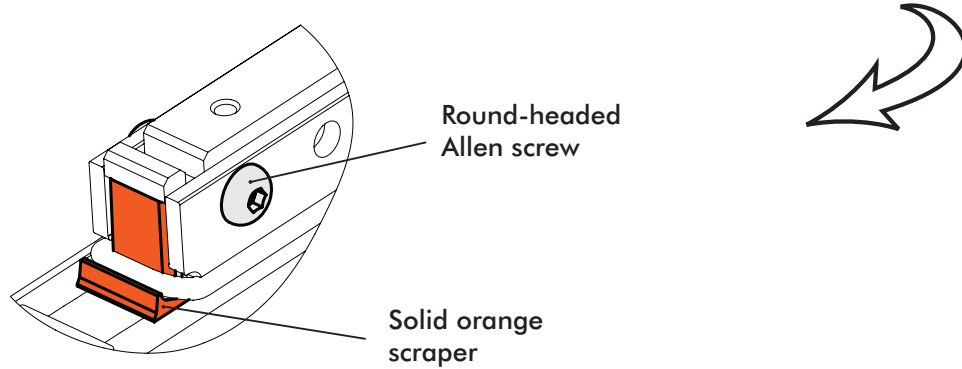

Available spare parts:

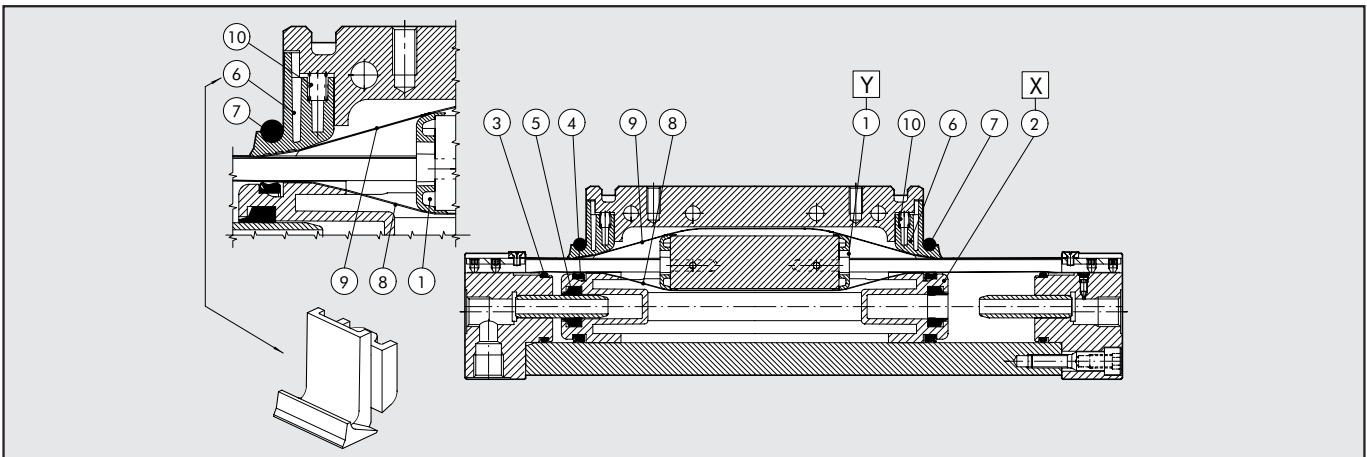

- ① Band support kit
- ② Piston kit
- ③ ④ ⑤ ⑥ ⑦ ⑩ Kit of NBR gaskets (Viton® for ⑦)
- ③ ④ ⑤ ⑥ ⑦ ⑩ Kit of Viton® gaskets
- ⑧ ⑨ Band kit (internal/external)

Spare part label affixed to one side of the cylinder

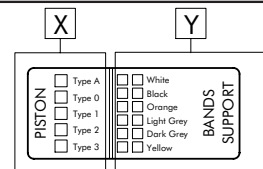

Spare part codes:

BAND SUPPORT KIT POS. N° 1 (Y)

Ø	Code White	Code Black	Code Orange	Code Light grey	Code Dark grey	Code Yellow
16	0090165080	0090165081	0090165082	0090165083	0090165084	0090165085
25	0090255080	0090255081	0090255082	0090255083	0090255084	0090255085
32	0090325080	0090325081	0090325082	0090325083	0090325084	0090325085
40	0090405080	0090405081	0090405082	0090405083	0090405084	0090405085
63	*0090635080	*0090635081	*0090635082	*0090635083	*0090635084	*0090635085

* For $\varnothing 63$ the kit is comprised of 1 band support and 1 shim in the ordered.
So for each cylinder $\varnothing 63$, order 2 kits.

BAND KIT (internal and external) Pos. n° 8-9

Ø	Code
16	0090166...
25	0090256...
32	0090326...
40	0090406... ... = STROKE
63	0090636...

KIT OF NBR GASKETS Pos. n° 3-4-5-6-7-10

Ø	Code
16	0090165022*
25	0090255022
32	0090325022
40	0090405022
63	0090635022

KIT OF VTN GASKETS Pos. n° 3-4-5-6-7-10

Ø	Code
16	0090165023*
25	0090255023
32	0090325023
40	0090405023
63	0090635023

PISTON KIT POS. N° 2 (X)

Ø	Code		Code		Code	
	Type 0 (0 rings)	Type 1 (1 rings)	Type 2 (2 rings)	Type 3 (3 rings)	Type A (4 rings)	
16	0090165015	0090165016	0090165017	0090165018	-	
25	0090255015	0090255016	0090255017	0090255018	-	
32	0090325015	0090325016	0090325017	0090325018	0090325019	
40	0090405015	0090405016	0090405017	0090405018	-	
63	0090635015	0090635016	0090635017	0090635018	-	

* 2 cushioning gaskets will be supplied with these codes
(a small series for the "last release" and a large one for the other two "releases").

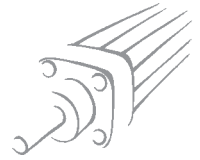

The cylinder is an **INTERMEDIATE RELEASE** if the end of carriage looks like this:

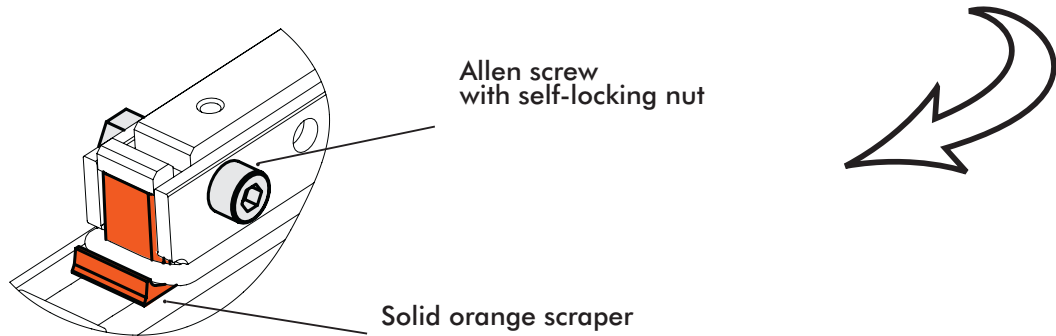

Available spare parts:

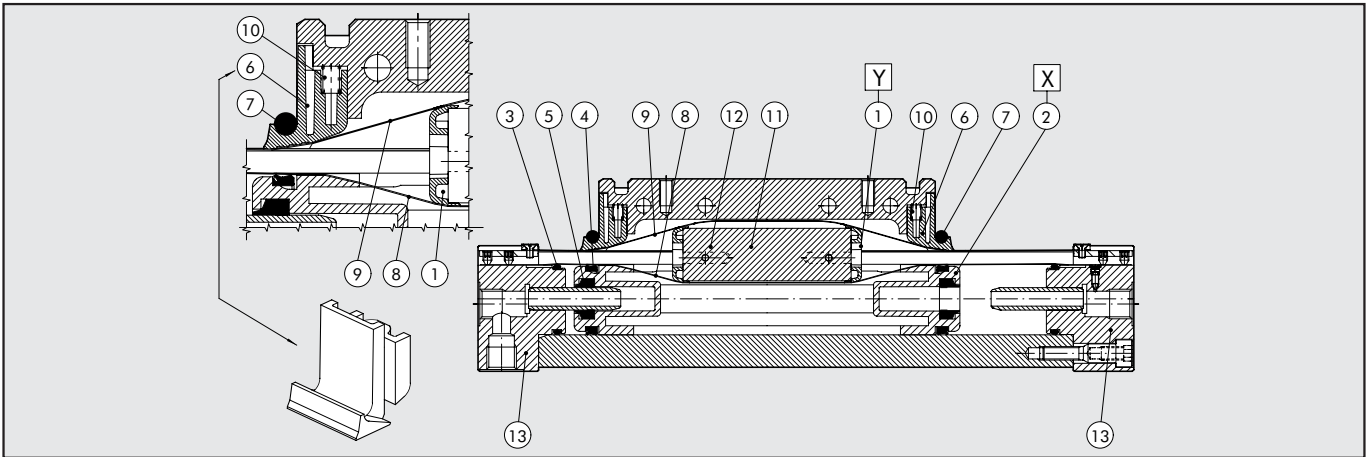

- ① Band support kit - **UNCHANGED**
- ② Piston kit - **CANCELLED AND REPLACED**
- ③ ④ ⑤ ⑥ ⑦ ⑩ Kit of NBR gaskets (Viton® for ⑦) - **UNCHANGED**
- ③ ④ ⑤ ⑥ ⑦ ⑩ Kit of Viton® gaskets - **UNCHANGED**
- ⑧ ⑨ Band kit (internal/external) - **UNCHANGED**
- ⑪ ⑫ Carriage kit - **NEW**
- ⑬ Right and left heads kit (for ø16) - **NEW**

Spare part label affixed to one side of the cylinder

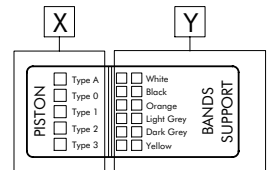

Unchanged spare part codes:

BAND SUPPORT KIT POS. N° 1 (Y)						
Ø	Code White	Code Black	Code Orange	Code Light grey	Code Dark grey	Code Yellow
16	0090165080	0090165081	0090165082	0090165083	0090165084	0090165085
25	0090255080	0090255081	0090255082	0090255083	0090255084	0090255085
32	0090325080	0090325081	0090325082	0090325083	0090325084	0090325085
40	0090405080	0090405081	0090405082	0090405083	0090405084	0090405085

BAND KIT (internal / external) Pos. n° 8-9	
Ø	Code
16	0090166...
25	0090256...
32	0090326...
40	0090406... ... = STROKE

KIT OF NBR GASKETS Pos. n° 3-4-5-6-7-10

Ø	Code
16	0090165022*
25	0090255022
32	0090325022
40	0090405022

KIT OF VITN GASKETS Pos. n° 3-4-5-6-7-10

Ø	Code
16	0090165023*
25	0090255023
32	0090325023
40	0090405023

* 2 cushioning gaskets will be supplied with these codes (a small series for "last release" and a larger one for the other two "releases").

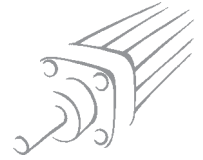

ATTENTION:

Since the pistons in the "INTERMEDIATE RELEASE" are no longer available the following codes are cancelled:

PISTON KIT POS. N° 2 (X)					
Ø	Code Type 0 (0 rings)	Code Type 1 (1 ring)	Code Type 2 (2 rings)	Code Type 3 (3 rings)	Code Type A (4 rings)
16	0090165010	0090165011	0090165012	0090165013	-
25	0090255010	0090255011	0090255012	0090255013	-
32	0090325010	0090325011	0090325012	0090325013	0090325014
40	0090405010	0090405011	0090405012	0090405013	-

and the following two kits (three for Ø16) must be ordered:

PISTON KIT POS. N° 2 (X)					
Ø	Code Type 0 (0 ring)	Code Type 1 (1 ring)	Code Type 2 (2 rings)	Code Type 3 (3 rings)	Code Type A (4 rings)
16	0090165015	0090165016	0090165017	0090165018	-
25	0090255015	0090255016	0090255017	0090255018	-
32	0090325015	0090325016	0090325017	0090325018	0090325019
40	0090405015	0090405016	0090405017	0090405018	-

CARRIAGE KIT FOR 270** Pos. n° 11-12

Ø	Code
16	0090165053*
25	0090255053
32	0090325053
40	0090405053

CARRIAGE KIT FOR 271** Pos. n° 11-12

Ø	Code
16	0090165054*
25	0090255054
32	0090325054
40	0090405054

CARRIAGE KIT FOR 272** Pos. n° 11-12

Ø	Code
16	0090165055*
25	0090255055
32	0090325055

RIGHT AND LEFT HEADS KIT Pos. n° 13

Ø	Code
16	0090165032

* For Ø16 must be ordered the "heads kit" also

** **IMPORTANT: specify the type of cylinder (first three digits of the code), when you choose the carriage kit**

NB:

If the cancelled piston need to be replaced:

- for Ø 16, in addition to the new piston kit, it will be necessary to order the "RIGHT AND LEFT HEADS KIT" and the carriage kit of the type being used.
- for Ø 25,32 and 40, in addition to the piston, it will be only necessary to order the carriage kit of the type being used.

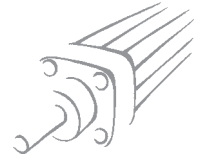

The cylinder is an **OLD RELEASE** if the end of the carriage looks like this:

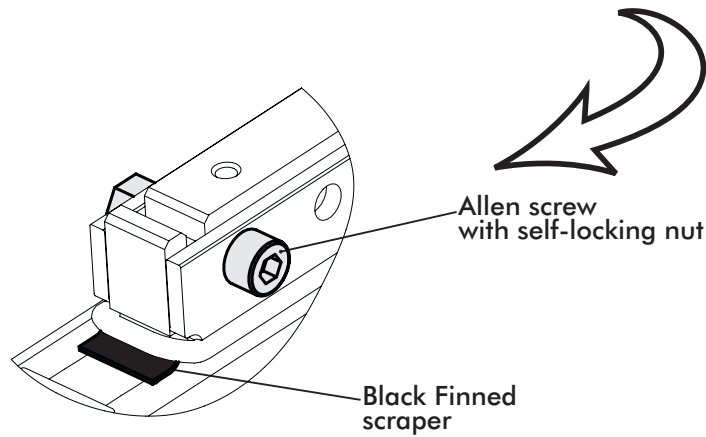

Available spare parts:

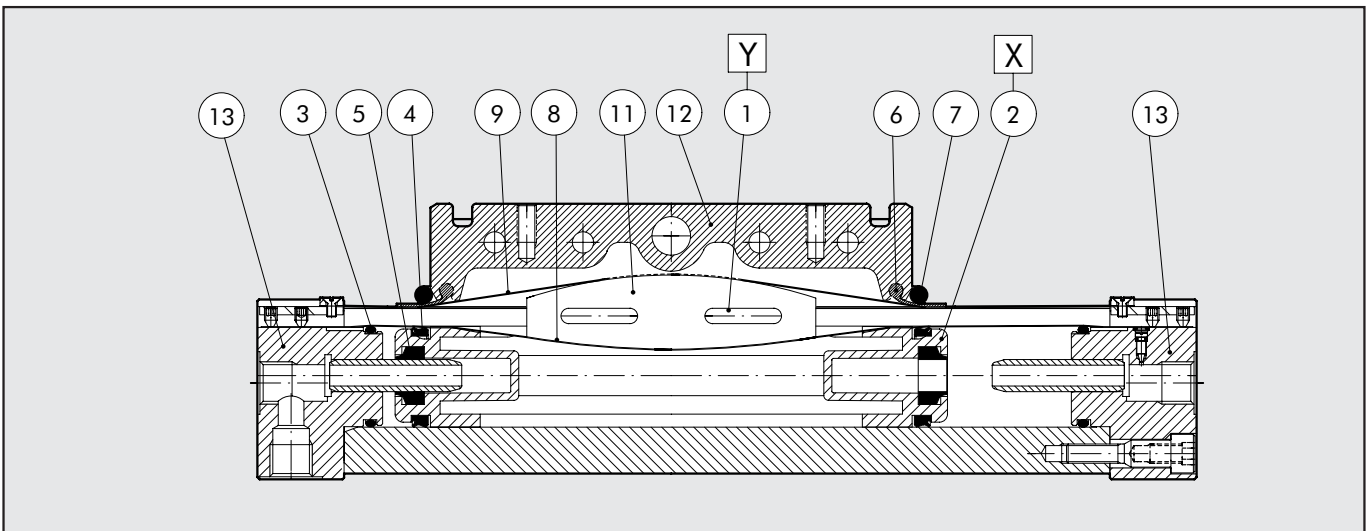

- ① Guiding plate kit - **CANCELLED AND REPLACED FROM BAND SUPPORT KIT (SEE CORRESPONDANCE TABLE)**
- ② Piston kit - **CANCELLED AND REPLACED**
- ③ ④ ⑤ ⑥ ⑦ Kit of NBR gaskets (Viton® for ⑦) - **CANCELLED AND REPLACED**
- ③ ④ ⑤ ⑥ ⑦ Kit of Viton® gaskets - **CANCELLED AND REPLACED**
- ⑧ ⑨ Band kit (internal/external) - **UNCHANGED**
- ⑪ ⑫ Carriage kit - **NEW**
- ⑬ Right and left heads kit (per Ø16) - **NEW**

Spare part label affixed to one side of the cylinder

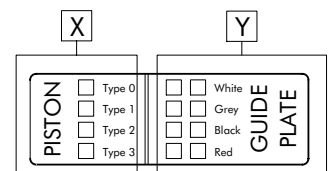

Unchanged spare parts:

BAND KIT (internal/external) pos. n° 8-9		
Ø	Code	
16	0090166...	
25	0090256...	
32	0090326...	
40	0090406...	...=STROKE

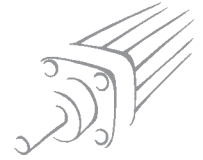

Since some of the components of the "OLD RELEASE" are no longer available, the following codes are cancelled:

GUIDING PLATE KIT POS. N° 1 (Y)				
Ø	Code	Code	Code	Code
Ø	White (0.9 mm)	Grey (1.0 mm)	Black (1.1 mm)	Red (1.2 mm)
16	0090165001	0090165002	0090165003	0090165004
25	0090255001	0090255002	0090255003	0090255004
32	0090325001	0090325002	0090325003	0090325004
40	0090405001	0090405002	0090405003	0090405004

KIT OF NBR GASKETS pos. n° 3-4-5-6-7	
Ø	Code
16	0090165020
25	0090255020
32	0090325020
40	0090405020

KIT OF VTN GASKETS pos. n° 3-4-5-6-7	
Ø	Code
16	0090165021
25	0090255021
32	0090325021
40	0090405021

PISTON KIT POS. N° 2 (X)					
Ø	Code	Code	Code	Code	Code
Ø	Type 0 (0 ring)	Type 1 (1 ring)	Type 2 (2 rings)	Type 3 (3 rings)	Type A (4 rings)
16	0090165010	0090165011	0090165012	0090165013	-
25	0090255010	0090255011	0090255012	0090255013	-
32	0090325010	0090325011	0090325012	0090325013	0090325014
40	0090405010	0090405011	0090405012	0090405013	-

and replaced by:

PISTON KIT POS. N° 2 (X)					
Ø	Code	Code	Code	Code	Code
Ø	Tipo 0 (0 anelli)	Type 1 (1 rings)	Type 2 (2 rings)	Type 3 (3 rings)	Type A (4 rings)
16	0090165015	0090165016	0090165017	0090165018	-
25	0090255015	0090255016	0090255017	0090255018	-
32	0090325015	0090325016	0090325017	0090325018	0090325019
40	0090405015	0090405016	0090405017	0090405018	-
63	0090635015	0090635016	0090635017	0090635018	-

KIT OF NBR GASKETS pos. n° 3-4-5-6-7-10	
Ø	Code
16	0090165022*
25	0090255022
32	0090325022
40	0090405022
63	0090635022

KIT OF VTN GASKETS pos. n° 3-4-5-6-7-10	
Ø	Code
16	0090165023*
25	0090255023
32	0090325023
40	0090405023
63	0090635023

* 2 cushioning gaskets will be supplied with these codes (a small series for the "last release" and a large one for the other two)

to which have to be added the carriage kit, the right and left heads kit and the band support kit:

CARRIAGE KIT FOR 270** pos. n° 11-12	
Ø	Code
16	0090165053*
25	0090255053
32	0090325053
40	0090405053

CARRIAGE KIT FOR 271** pos. n° 11-12	
Ø	Code
16	0090165054*
25	0090255054
32	0090325054
40	0090405054

CARRIAGE KIT FOR 272** pos. n° 11-12	
Ø	Code
16	0090165055*
25	0090255055
32	0090325055

RIGHT AND LEFT HEADS KIT pos. n° 13	
Ø	Code
16	0090165032

Ø	GUIDING PLATE	BAND SUPPORT KIT	GUIDING PLATE	BAND SUPPORT KIT	GUIDING PLATE	BAND SUPPORT KIT	GUIDING PLATE	BAND SUPPORT KIT
16	WHITE	White 0090165080	GREY	Orange 0090165082	BLACK	Dark grey 0090165084	RED	Yellow 0090165085
25		Yellow 0090255085		Black 0090255081		Light grey 0090255083		Dark grey 0090255084
32		White 0090325080		Black 0090325081		Light grey 0090325083		Dark grey 0090325084
40		White 0090405080		Black 0090405081		Light grey 0090405083		Dark grey 0090405084

* For Ø16 the head kit must be ordered as well

** **IMPORTANT: specify the type of cylinder (first three digits of the code), when you choose a carriage kit.**

NB:

If the cancelled pistons, plates or the gaskets need to be replaced:

- for Ø 16, in addition to the new piston kit, it will be necessary to order the "kit of the RH and LH heads", the carriage kit of the type being used and the band support kit as shown in the table.
- for Ø 25,32 and 40, as above, except for the kit of RH and LH heads.